

User Manual
BLIZZARD-60
CMOS Area Scan Cameras

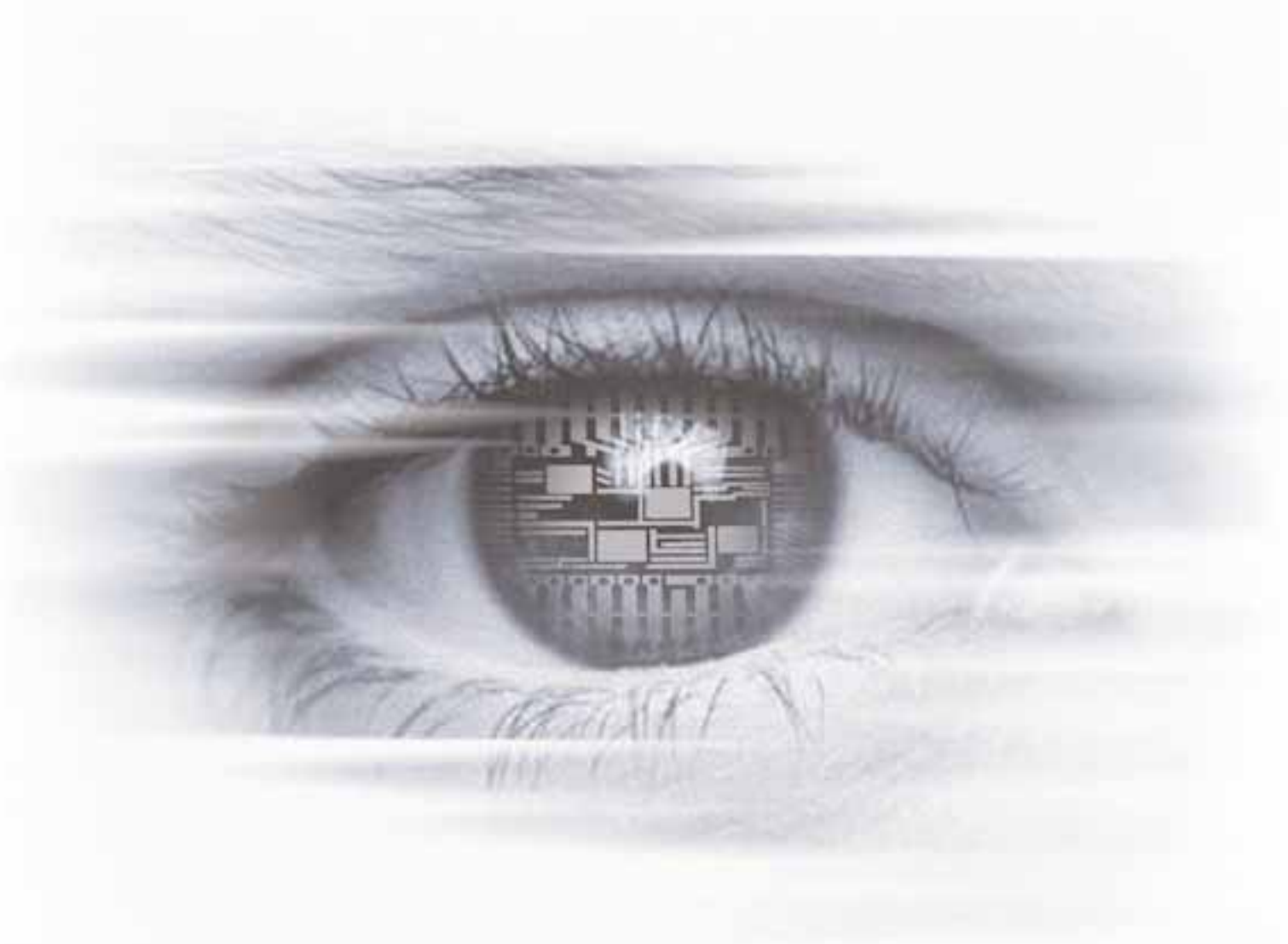

THE PERFECT EYE

All information provided in this manual is believed to be accurate and reliable. No responsibility is taken by Photonfocus AG for its use. Photonfocus AG reserves the right to make changes to this information without notice.

Reproduction of this manual in whole or in part, by any means, is prohibited without prior permission having been obtained from Photonfocus AG.



Contents

1 Preface	5
1.1 About Photonfocus	5
1.2 Contact	5
1.3 Sales Offices	5
1.4 Further information	5
2 How to get started	7
2.1 CameraLink	7
2.2 USB 2.0	10
3 Product Specification	13
3.1 Introduction	13
3.2 Technical Specifications	14
3.3 Feature Overview	16
3.4 Further Information	16
3.4.1 Frame grabber Relevant Configuration Parameters (CameraLink only)	16
3.4.2 USB 2.0 Interface	16
4 Functionality	17
4.1 Image Acquisition	17
4.1.1 Free Running and External Trigger Mode	17
4.1.2 Exposure Control	17
4.1.3 Maximum Frame Rate	17
4.1.4 Active Pixel Array and End-of-Line Pattern	17
4.2 Linear and Non-linear Pixel Response	18
4.2.1 Gain x1 to x8	18
4.2.2 LinLog	19
4.2.3 Skimming	21
4.2.4 Image Correction	21
4.3 Reduction of Image Size	22
4.3.1 Region of Interest	22
4.3.2 Decimation Y 1:2	24
4.4 Trigger modes	24
4.5 Configuration Interface	24
4.5.1 CameraLink Serial Interface	24
4.5.2 USB 2.0 Interface	25
5 Hardware Interface	27
5.1 Connectors	27
5.1.1 CameraLink Connector	27
5.1.2 USB 2.0 Connector	28
5.1.3 Power Supply	29
5.1.4 Trigger Signals (USB only)	29

5.1.5	Status Indicator	30
5.2	CameraLink Data Interface	31
5.3	Read-Out Timing	32
5.3.1	Standard Read-out Timing	32
5.4	Trigger	34
5.4.1	Overview	34
5.4.2	External Trigger Mode	34
5.4.3	Notes on Using External Trigger	35
6	The PFRemote Control Tool	37
6.1	Overview	37
6.1.1	CameraLink Model	37
6.1.2	USB 2.0 Model	37
6.2	Installation Notes (CameraLink only)	38
6.2.1	DLL Dependencies	38
6.3	Usage	39
6.3.1	Camera Initialization	39
6.3.2	The Camera Configuration Dialog	40
7	Mechanical and Optical Considerations	45
7.1	Mechanical Dimensions	45
7.2	Optical Interface	46
7.2.1	Mounting the Lens	46
7.2.2	Cleaning the Sensor	46
7.3	Compliance	48
8	Warranty	49
8.1	Warranty Terms	49
8.2	Warranty Claim	49
A	Pinouts	51
A.1	Power Supply	51
A.1.1	Power Supply Connector for CameraLink Model	51
A.1.2	Power Supply Connector for USB Model	52
A.2	CameraLink	53
A.3	USB 2.0	54
B	USB compatibility	55
B.1	Hardware requirements	55
C	Literature and Links	59
D	Revision History	61

Preface

1.1 About Photonfocus

The Swiss company Photonfocus is one of the leading specialists in the development of CMOS image sensors and corresponding industrial cameras for machine vision, security & surveillance and automotive markets.

Photonfocus is dedicated to making the latest generation of CMOS technology commercially available. Active Pixel Sensor (APS) and global shutter technologies enable high speed and high dynamic (120 dB) applications, while avoiding the disadvantages, e.g. image lag, blooming and smear.

Photonfocus has proven that the image quality of modern CMOS sensors is now appropriate for demanding applications. Photonfocus' product range is complemented by custom design solutions in the area of camera electronics and CMOS image sensors.

Photonfocus is ISO 9001 certified. All products are produced with the latest techniques in order to ensure the highest degree of quality.

1.2 Contact

Photonfocus AG, Bahnhofplatz 10, CH-8853 Lachen, Switzerland

Sales	Phone: +41 55 451 01 31	Email: sales@photonfocus.com
Support	Phone: +41 55 451 01 37	Email: support@photonfocus.com

Table 1.1: Photonfocus Contact

1.3 Sales Offices

Photonfocus products are available through an extensive international distribution network; details of the distributor nearest you can be found at www.photonfocus.com.

1.4 Further information

For further information on the products, documentation and software updates please see our web site www.photonfocus.com or contact our distributors.



Photonfocus reserves the right to make changes to its products without notice. Photonfocus products are neither intended nor certified for use in life support systems or in other critical systems. The use of Photonfocus products in such applications is prohibited.



Photonfocus and LinLog are trademarks of Photonfocus AG. CameraLink is a registered mark of the Automated Imaging Association. Product and company names mentioned herein are trademarks or trade names of their respective companies.

How to get started

2.1 CameraLink

1. Install a suitable frame grabber in your PC.



To find a compliant frame grabber, please see the frame grabber compatibility list at www.photonfocus.com.



For US and Canada: Ensure the device downstream of the camera data path (e.g. camera power supply, cable, frame grabber and PC) is UL listed.

2. Install the frame grabber software.



Without installed frame grabber software the camera configuration tool PFRemote will not be able to communicate with the camera. Please follow the instructions of the frame grabber supplier.

3. Remove the camera from its packaging. Please make sure the following items are included with your camera:

- Power supply connector (3-pole power plug)
- Camera body cap

If any items are missing or damaged, please contact your dealership.

4. Remove the camera body cap from the camera and mount a suitable lens.

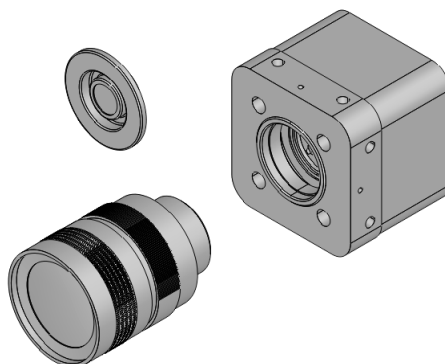

Figure 2.1: Camera with protective cap and lens.



Do not touch the sensor surface. Protect the image sensor from particles and dirt! When removing the protective cap or changing the lens, the camera should always be held with the opening facing downwards to prevent dust from the environment falling onto the CMOS sensor. If the lens is removed, the protective cap should be refitted.



To choose a suitable lens for your application, see the Lens Finder in the 'Support' area at www.photonfocus.com.

5. Connect the camera to the frame grabber with a suitable CameraLink cable (see Fig. 2.2).

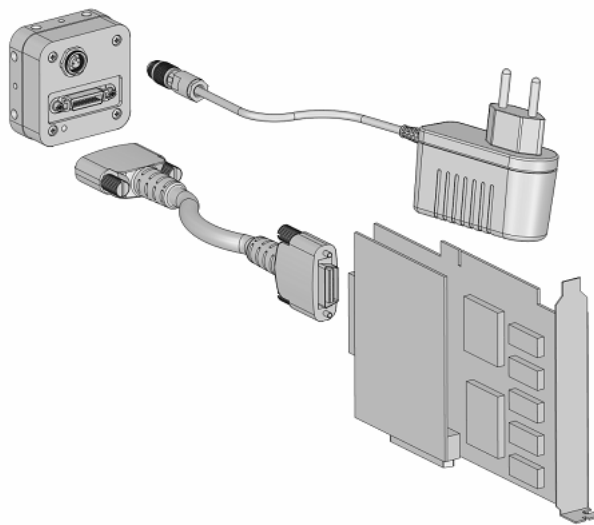

Figure 2.2: Camera with frame grabber, power supply and cable.



Do not connect or disconnect the CameraLink cable while camera power is on! For more information about CameraLink see Section 4.5.

6. Connect a suitable power supply to the provided 3-pole power plug. For the connector assembly see Fig. A.1.



Check the correct supply voltage and polarity! Do not exceed the maximum operating voltage of +12V DC ($\pm 10\%$).



The pinout of the connector is shown in Section A.1.



For US and Canada: Ensure a UL listed power supply is used. A suitable UL listed power supply is available from Photonfocus.

7. Connect the power supply to the camera (see Fig. 2.2).



The status LED on the rear of the camera will light red for a short moment, and then flash green. For more information see Section 5.1.5.

8. Download the camera software PFRemote to your computer.



You can find the latest version of PFRemote on the support page at www.photonfocus.com.

9. Install the camera software PFRemote. Please follow the instructions of the PFRemote setup wizard.

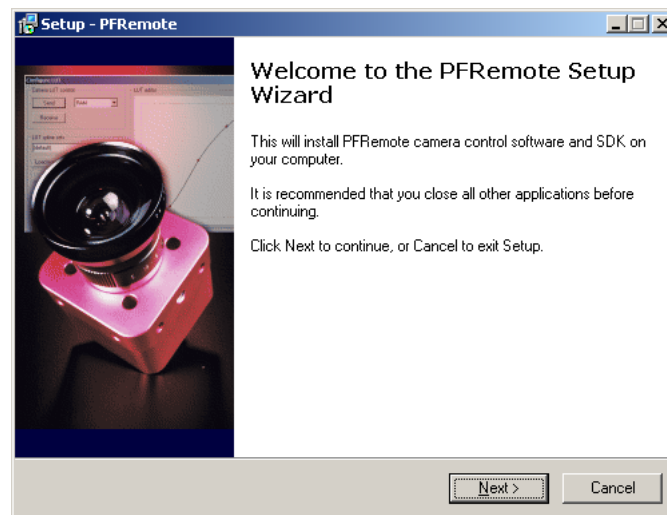

Figure 2.3: Screen shot PFRemote setup wizard

10. Start the camera software PFRemote and choose the communication port (e.g. cl0, com0, siso0).

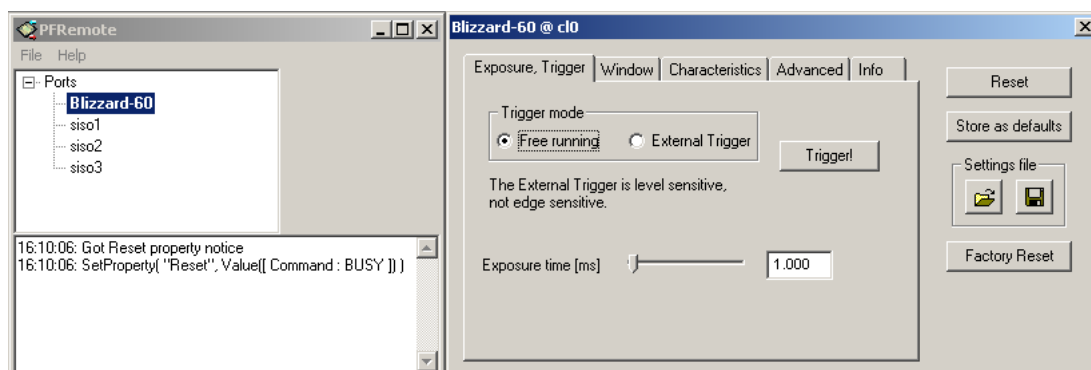

Figure 2.4: PFRemote start window

11. Check the status LED on the rear of the camera.



The status LED lights green when an image is being produced, and it is red when serial communication is active. For more information see Section 5.1.5.

12. You may now display images using the software that is provided by the frame grabber manufacturer.



The camera delivers images with a resolution of 10 bit. Please refer to the documentation of your frame grabber how to receive 10 bit images.

2.2 USB 2.0

1. Remove the camera from its packaging. Please make sure the following items are included with your camera:

- Power supply connector (7-pole power plug)
- Camera body cap
- Installation CD (Driver/Application CD)

If any items are missing or damaged, please contact your dealership.



Please check that your PC's chipset is supported before you proceed (see Section 4.5.2).

2. Remove the camera body cap from the camera and mount a suitable lens.

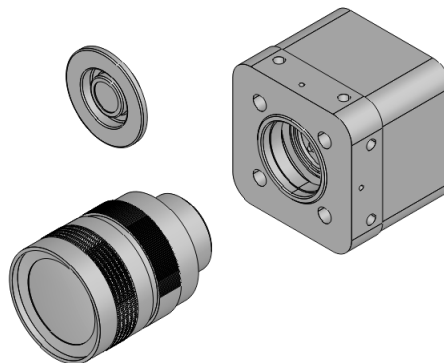



Figure 2.5: Camera with protective cap and lens.



Do not touch the sensor surface. Protect the image sensor from particles and dirt! When removing the protective cap or changing the lens, the camera should always be held with the opening facing downwards to prevent dust from the environment falling onto the CMOS sensor. If the lens is removed, the protective cap should be refitted.

 To choose a suitable lens for your application, see the Lens Finder in the 'Support' area at www.photonfocus.com.

3. Install the USB camera software called MicroDisplayUSB.

 After installation of the USB 2.0 device driver, *any other USB 2.0 devices connected to this controller will be ignored*. USB 1.1 devices, on the other hand, can still be operated.

4. Connect the camera to a USB 2.0 port at the PC with a suitable USB 2.0 cable (see Fig. 2.6).

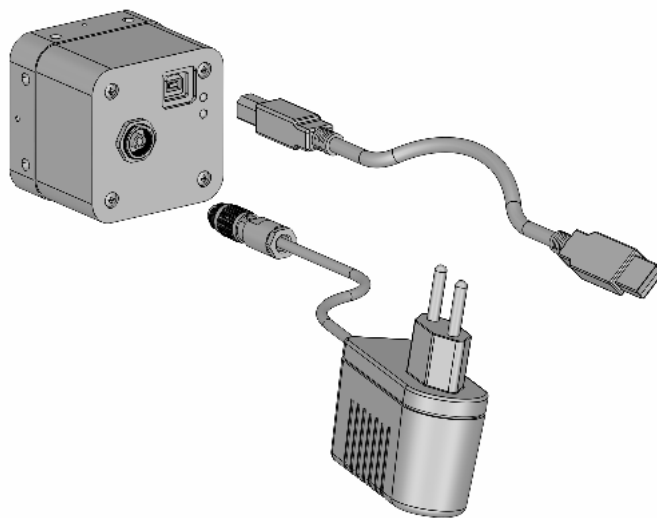





Figure 2.6: Camera with power supply and USB 2.0 cable.

5. Connect a suitable power supply to the provided 7-pole power plug. For the connector assembly see Fig. A.1.

 Check the correct supply voltage and polarity! Do not exceed the maximum operating voltage of +12V DC ($\pm 10\%$).

 The pinout of the connector is shown in Section A.1.

 For US and Canada: Ensure a UL listed power supply is used. A suitable UL listed power supply is available from Photonfocus.

6. Start the software "MicroDisplayUSB". In the **Camera Selection** window (see Fig. 2.7), choose the camera model and press OK. This step is mandatory for proper operation of the camera, because it uploads the USB firmware into the camera.

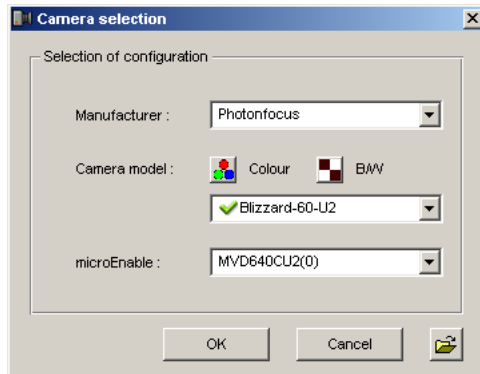



Figure 2.7: MicroDisplayUSB camera selection window



If the power supply or the USB cable of the camera have been disconnected, you have to restart MicroDisplayUSB in order to download the USB firmware again.

7. Start the camera software "PFRremote" and choose the communication port USB0 (see Fig. 2.4).
8. Check the status LEDs on the rear of the camera
 The status LED 2 (lower one) lights green when an image is being produced, and it is red when serial communication is active. The LED 1 (upper one) lights green when USB is ready and blinks red depending of the transfer mode. For more information see Section 5.1.5.
9. You may now display images using the MicroDisplayUSB software.

Product Specification

3.1 Introduction

The BLIZZARD-60 series of CMOS cameras from Photonfocus is aimed at demanding applications in industrial image processing. It provides an exceptionally high dynamic range of up to 120 dB at a resolution of 750 x 400 pixels and a frame rate of up to 60 full images per second. The cameras are built around a monochrome CMOS image sensor, developed by Photonfocus. The principal advantages are:

- Low power consumption at high speeds
- Resistance to blooming
- Extremely high image contrast achieved by LinLog technology.
- The global shutter, in combination with a selectable region of interest, is ideal for high speed applications
- Software is provided to set camera parameters and store them within the camera.
- The cameras have a digital CameraLink or a USB 2.0 interface.
- The compact size of only 55 x 55 x 24 mm³ (CameraLink) or 55 x 55 x 48 mm³ (USB 2.0) makes the BLIZZARD-60 series the perfect solution for applications in which space is at a premium.

The general specifications and features of the camera are listed in the following sections.

3.2 Technical Specifications

	<i>BLIZZARD-60</i>
Technology	CMOS active pixel
Scanning system	progressive scan
Optical format / diagonal	2/3" / 9 mm
Resolution	750 x 400 pixels (active 748 x 400)
Pixel size	10.6 x 10.6 μm^2
Active optical area	7.95 x 4.30 mm
Random noise	< 1.5 DN RMS @ 10 bit / gain = 1
Fixed pattern noise (FPN)	< 15 DN RMS @ 10 bit / gain = 1
Dark current	2 fA/pixel @ 30°C
Full well capacity	200 ke ⁻
Spectral sensitivity	380 nm ... 950 nm
Responsivity	480x10 ³ DN/(J/m ²) @ 610nm / 10 bit / gain = 1
Optical fill factor	35% (diode area only)
Dynamic range	60 dB linear, 120 dB (with LinLog)
Color format	monochrome
Characteristic curve	linear or LinLog
Shutter mode	global shutter
Readout mode	non-interleaved
Min. Region of Interest (ROI)	1 row x 6 columns

Table 3.1: Image sensor specifications



The last two columns of every image consist of an end of line (EOL) pattern which cannot be turned off. Therefore, the maximum active resolution is 748 x 400 pixels, but an image of 750 x 400 pixels is output. The second to last column is always white and the last black. This also applies when using Region of Interest (see Section 4.3.1).

	<i>BLIZZARD-60</i>
Exposure Time	500 μ s ... 52 ms / 500 μ s steps (linear or LinLog mode)
	10 μ s ... 500 us / 10 μ s steps (linear mode only)
Frame Rate	60 fps @ Tint = 100 μ s
Pixel Clock	20 MHz
Camera Taps	1
Greyscale Resolution	10 bit
Programmable On-Chip Gain	x1 - x8 in 8 steps

Table 3.2: Camera specifications

	<i>BLIZZARD-60 CL</i>	<i>BLIZZARD-60 USB</i>
Operating Temperature	0°C ... 60°C	0°C ... 60°C
Power Supply	+12 V DC (\pm 10%)	+12 V DC (\pm 10%)
Power Consumption	0.8 W	2.2 W
Lens Mount	C- or CS-Mount	C- or CS-Mount
Dimensions	55 x 55 x 24 mm ³	55 x 55 x 48 mm ³
Mass	150 g	200 g
Conformity	CE	CE

Table 3.3: Physical characteristics

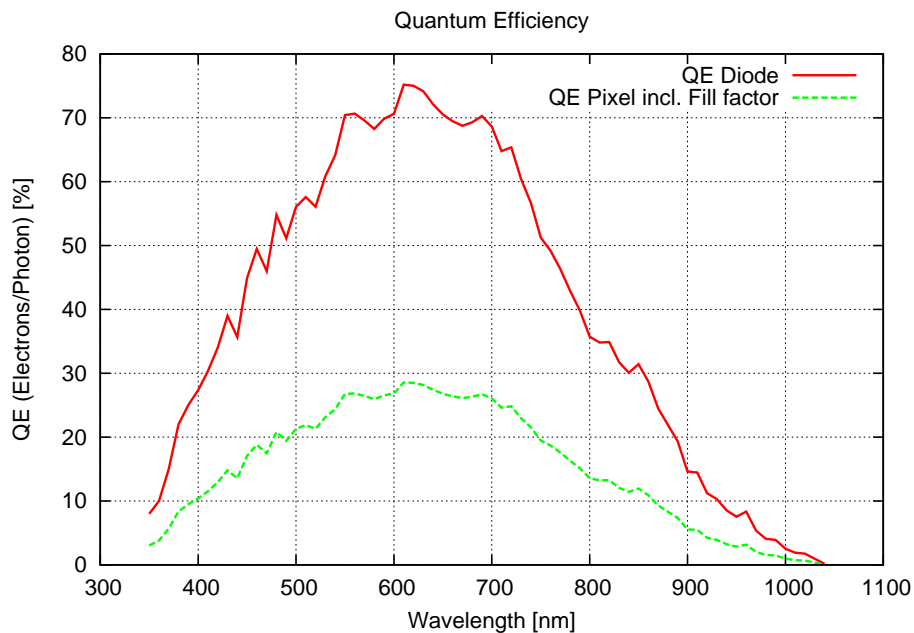

Figure 3.1: Spectral response

3.3 Feature Overview

	<i>BLIZZARD-60</i>
Interfaces	CameraLink base configuration or USB 2.0 Interface
Camera Control	PFRemote (Windows GUI) or programming library (Windows)
Configuration Interface	CLSERIAL (9'600 baud / higher baud rates on request)
Trigger Modes	Free running / ExSync controlled
Features	Region of Interest (ROI)
	LinLog / Skimming / Decimation (Y 1:2) / Analog gain

Table 3.4: Camera configuration

3.4 Further Information

3.4.1 Frame grabber Relevant Configuration Parameters (CameraLink only)

	<i>BLIZZARD-60 CameraLink</i>
Pixel Clock	20 MHz
Number of Taps	1
Greyscale Resolution	10 bit
CC-Signals	CC1: EXSYNC (common trigger signal, <i>level sensitive</i>), CC2, CC3, CC4: not used

Table 3.5: Camera specification



The trigger signal is level sensitive, it is not edge controlled! Keep the applied EXSYNC-Signal as short as possible (100ns up to configured exposure time). Please consult your frame grabber manual whether your grabber is capable of processing such trigger pulses.

3.4.2 USB 2.0 Interface

During the software installation, the original Windows USB 2.0 driver is replaced by a highly performance-optimized driver from Silicon Software. To take full advantage of your camera, a PC mainboard with Intel chip set is mandatory. Chip sets from VIA can achieve only half of the maximum frame rate. Other chip sets are currently not supported (see Section 4.5.2).



After installation of the USB 2.0 device driver, any other USB 2.0 devices connected to this controller will be ignored. USB 1.1 devices, on the other hand, can still be operated.

Functionality

This chapter serves as an overview over the camera configuration modes and explains camera features. The goal is to describe what can be done with the camera; the setup is explained in later chapters.

4.1 Image Acquisition

4.1.1 Free Running and External Trigger Mode

By default the camera continuously delivers images with a certain configurable frame rate, which depends on the exposure and read-out time (free-running mode). When the acquisition of an image needs to be synchronised to an external event, a trigger can be used (refer to Section 4.4).

4.1.2 Exposure Control

The exposure time defines the period during which the image sensor is integrating the incoming light. See Table 3.2 for the range of exposure time which can be configured.

4.1.3 Maximum Frame Rate

The maximum frame rate depends on the exposure time and the size of the image (see Region of Interest, Section 4.3.1).

4.1.4 Active Pixel Array and End-of-Line Pattern

The BLIZZARD-60 Camera has an active pixel array of 748 columns x 400 rows. At the end of each row, a fixed pattern of gray level 0 (black) and then gray level 1023 (white, 10 bit resolution) will be transmitted as an End-of-Line (EOL).

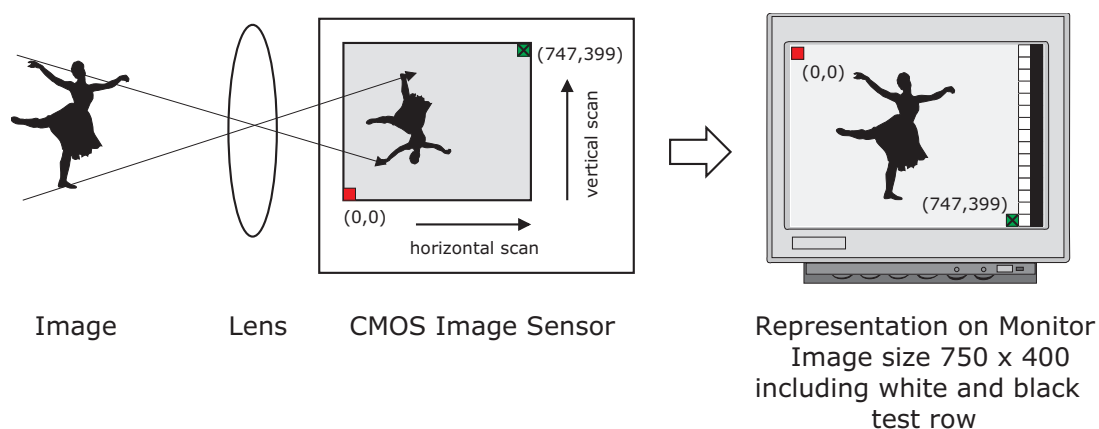

Figure 4.1: Acquired image at full resolution with test row



Every acquired image consists of the active pixel array information and the EOL pattern. The EOL pattern cannot be switched off.

4.2 Linear and Non-linear Pixel Response

Normally, the camera offers a substantially linear response between input light signal and output gray level. This can be modified by the use of LinLog or Skimming as described in the following sections.



In the following sections, the pixel response is illustrated by diagrams, which show the principle behaviour.

4.2.1 Gain x1 to x8

The gain of the programmable gain amplifier (PGA) can be configured between 1 and 8 with a resolution of 8 steps: x1 / x1.5 / x1.8 / x2.5 / x3 / x4.5 / x6 / x8.

Fig. 4.2 gives an example of the sensor response curve using different gain settings for Tint = 1ms.

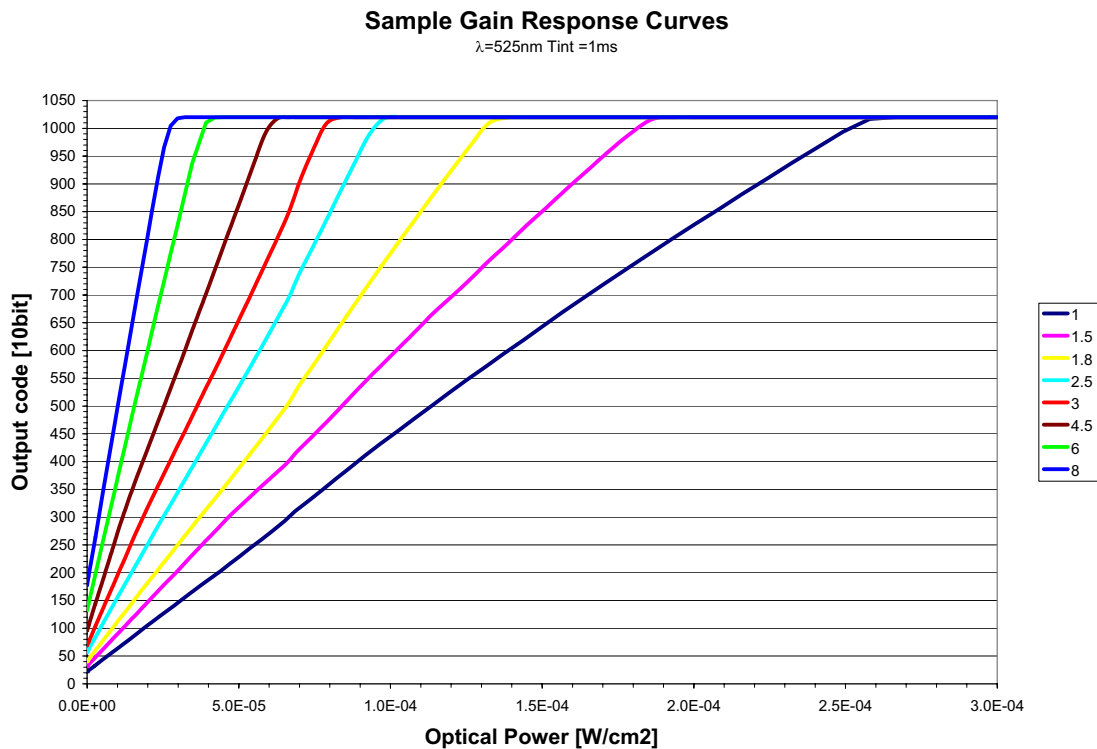

Figure 4.2: Response curve for different gain settings in linear mode



When using gain, LinLog and skimming in combination, the parameters for each feature have to be selected very carefully. Otherwise, the image quality may not satisfy.

4.2.2 LinLog

The LinLog feature of CMOS image sensors from Photonfocus allows the user to adapt the characteristics of the sensor to the requirements of the application. In situations involving high intrascene contrast, compression of the upper grey level region can be achieved with the LinLog technology. At low intensities, each pixel shows a linear response. At high intensities, the response changes to logarithmic compression. The transition region between linear and logarithmic response can be smoothly adjusted and is continuously differentiable and monotonic.

An example in the following section should illustrate the LinLog feature.

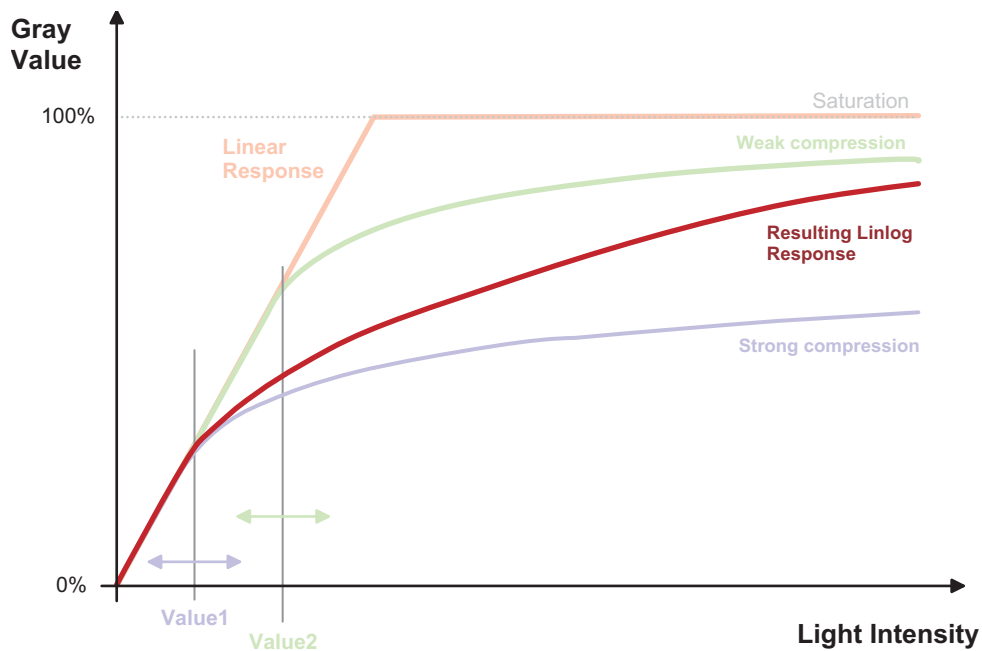

Figure 4.3: Resulting LinLog2 response curve

The BLIZZARD-60 has 4 parameters to control the LinLog mode (Time1, Time2, Value1 and Value2, see Fig. 4.4). The LinLog voltage (V_{LinLog}) that is applied to the sensor is decreased in two steps to 0 during the exposure time. A higher LinLog voltage means a stronger compression of the bright input light.

At exposure start, the LinLog voltage is equal to Value1. After Time1 finished, the LinLog voltage is decreased to a level equal to Value2. After Time2 ends, the LinLog voltage is decreased to zero (Value3) until the end of integration.

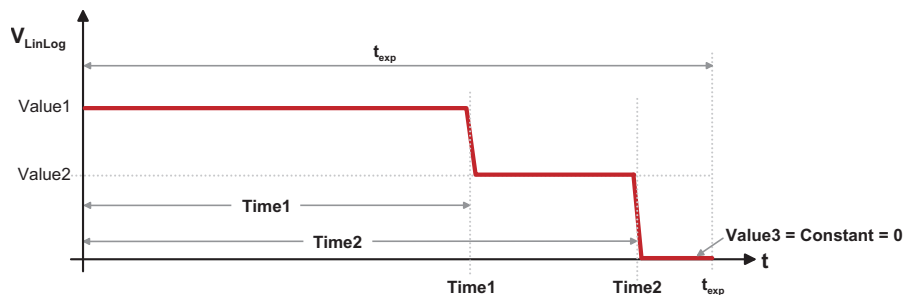

Figure 4.4: Linlog voltage switch

An example for a LinLog response curve is given in Fig. 4.5. The exposure time in this example was $T_{int} = 10 \text{ ms}$, and the step of the LinLog voltage from the programmed LinLog voltage to 0V occurs at 99% of the integration time. The decimal value in the legend corresponds to the LinLog settings `Value1`.

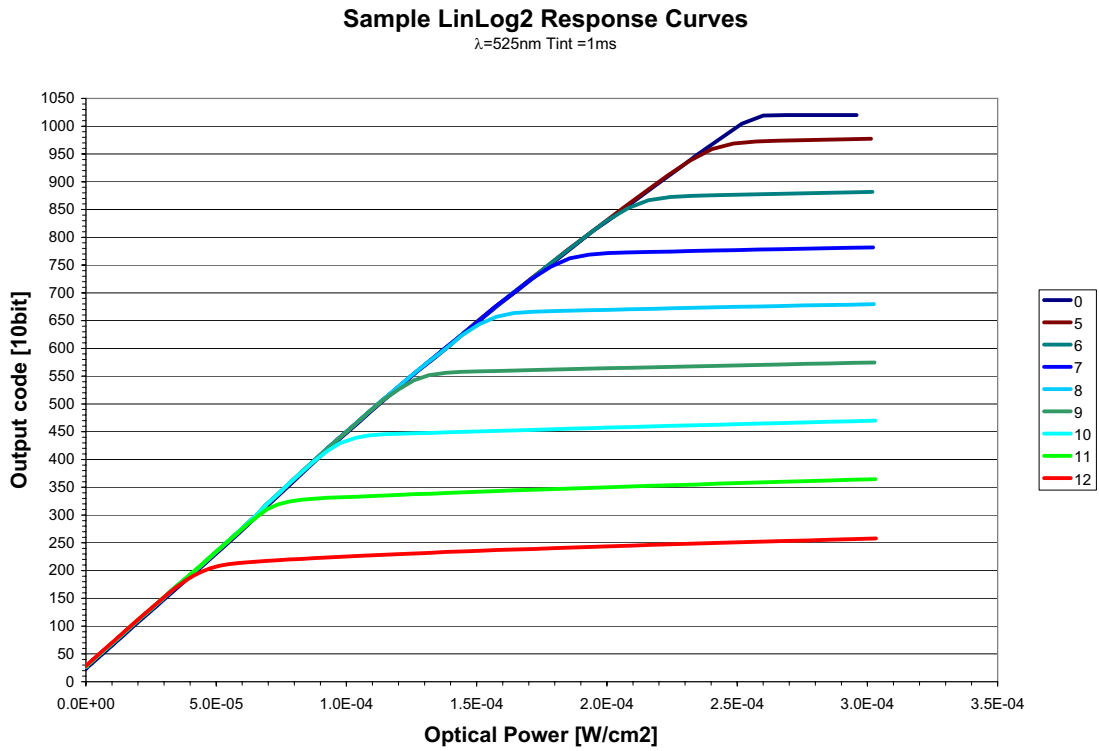

Figure 4.5: Response curve for different LinLog settings in LinLog2 mode

4.2.3 Skimming

Skimming is a Photonfocus proprietary technology to enhance detail in dark areas of an image. Skimming provides an adjustable level of in-pixel gain for low signal levels. It can be used together with LinLog to give a smooth monotonic transfer function from high gain at low levels, through normal linear operation, to logarithmic compression for high signal levels. The resulting response is similar to a gamma correction.

Fig. 4.6 shows an example of the sensor response curve for different skim voltages. The integration time was $T_{int} = 10$ ms. The decimal value in the legend corresponds to the skim settings.

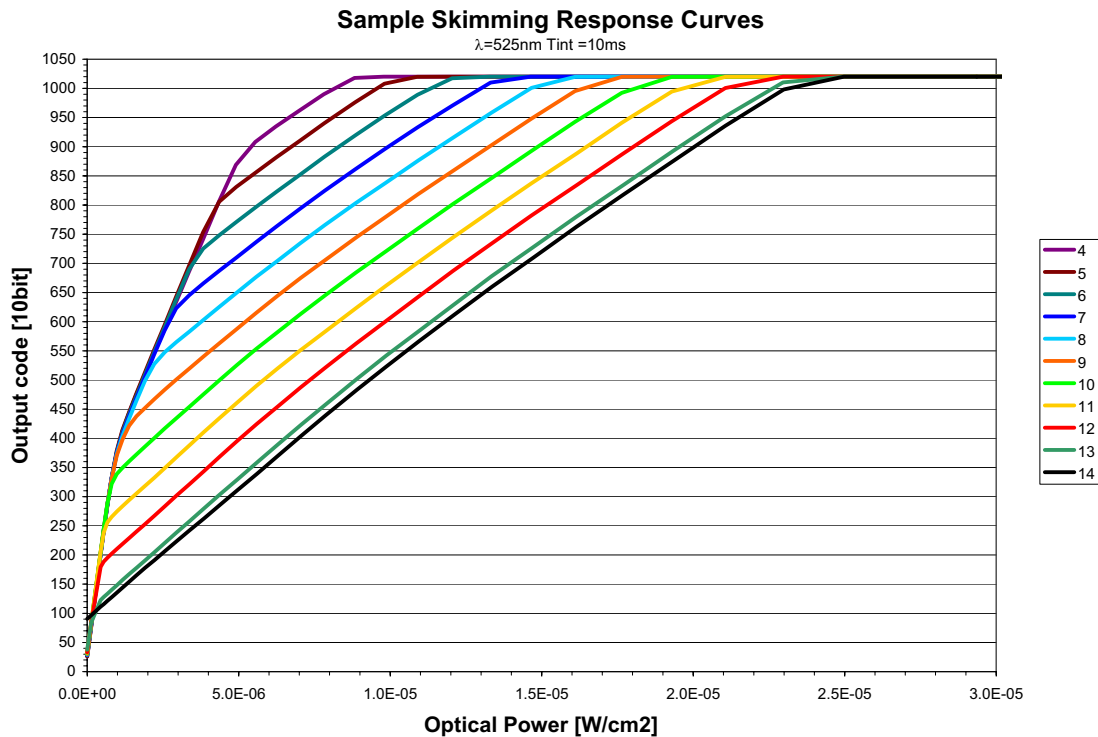

Figure 4.6: Response curve for different skim settings

4.2.4 Image Correction

On the BLIZZARD-60, there is a defect pixel correction available. It is implemented as a sliding window containing five pixels, which examines the current pixel and two pixels either side of it. If the current pixel exceeds the average of its neighbors by more than a certain user-defined threshold, the pixel will be rejected and replaced by this average value.

4.3 Reduction of Image Size

With Photonfocus cameras there are several possibilities to focus on the interesting parts of an image, thus reduce the data rate and increase the frame rate. The most commonly used feature is region of interest (ROI).

4.3.1 Region of Interest

Some applications do not need the full image resolution (e.g. 750 x 400 pixels). By reducing the image size to a certain region of interest (ROI), the frame rate can be greatly increased. A region of interest can be any rectangular window and is specified by its position within the full frame and its width and height. Fig. 4.7 gives some possible configurations for a region of interest, and Table 4.1 shows other examples on how the frame rate can be increased for the BLIZZARD-60 model by reducing the ROI.

 When using the skimming feature, the frame rate slightly decreases due to increased reset time of the sensor (see Table 4.2).

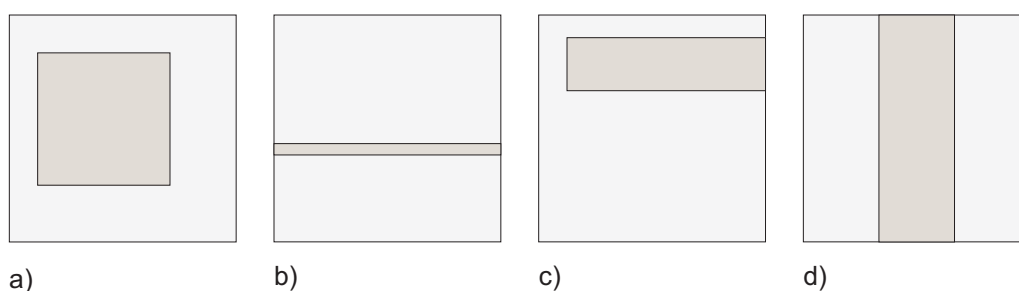

Figure 4.7: ROI configuration examples

The user can define a Region Of Interest (ROI) within the sensor to be transmitted to the frame grabber. The smallest ROI for the camera consists of one line of six pixels.

ROI Dimensions	Maximum frame rate
750 x 400	58 fps
750 x 200	110 fps
750 x 100	198 fps
750 x 1	956 fps
600 x 400	70 fps
400 x 400	98 fps
300 x 200	217 fps

Table 4.1: Example: Frame rate increase for a ROI ($T_{int} = 1ms$)



Please note that the last two pixels of every line are EOL pattern. The second to last line is always white and the last black. This also applies when using ROI (see Section 4.1.4).

<i>ROI Dimensions</i>	<i>Maximum frame rate</i>
750 x 400	58 fps
750 x 200	109 fps
750 x 100	194 fps
750 x 1	873 fps
600 x 400	70 fps
400 x 400	97 fps
300 x 200	212 fps

Table 4.2: Example: Frame rate increase for a ROI ($T_{Int} = 1ms$) when using skimming

The ROI parameter values must follow the rules according to 4.3. PFRremote and PFLib API respectively ensure that the settings are correct without any user intervention.

	Range	Step size
X	0, 4, 8, .. 740	modulo 4
W	6, 10, 14, .. 750	4
Y	0, 1, 2 .. 394	1
H	1, 2, 3 .. 400	1

Table 4.3: ROI size restriction

Calculation of the Maximum Frame Rate

The frame rate depends on the exposure time, trigger mode and skimming mode.

Frame time = (1 / frame rate)

Frame time > (exposure time + read out time)

Frame time > $T_{Int} + t_U \{ P_Y \cdot P_X + [(P_Y - 1) \cdot LP] + FS + CPRE1 + CPRE2 + SR \}$

t_U pixel clock period in ns (constant $t_U = 50.00$ ns)

T_{Int} exposure time (range $T_{Int} = 10 \mu s \dots 52$ ms)

LP line pause (constant LP = 61 clock cycles)

CPRE1 clocks between completed readout and before a new image acquisition begins
(External Trigger: CPRE1 = 0 clock cycles; Free running: CPRE1 = 62 clock cycles)

CPRE2 clocks between end of integration and before the data transfer begins
(constant CPRE2 = 28 clock cycles)

SR skim reset; additional clocks between end of integration and before the data transfer begins when skimming is active (skim = 0: SR = 0 clock cycles, skim > 0: SR = 1984 clock cycles)

FS frame start; clocks between rising edge FVAL and first LVAL (constant FS = 73 clock cycles)

P_X number of pixels in x-direction (6 ... 750 columns)

P_Y number of pixels in y-direction (1 ... 400 rows)

A frame rate calculator is available in the support area of the Photonfocus website.

4.3.2 Decimation Y 1:2

Decimation Y 1:2 (1:2 Y-axis subsampling) is another possibility to increase the frame rate. It transfers every 2nd row of an image and thus compresses the image height by factor 2. Decimation can also be used together with ROI.

4.4 Trigger modes

With a trigger signal the acquisition of an image can be synchronised with an external event. This trigger signal can be either generated by the frame grabber itself or it can be generated by an external source such as a light barrier.

For the BLIZZARD-60 cameras, there are 2 different trigger modes available:

External Trigger Mode In this trigger mode the camera is configured with a certain exposure time. A trigger pulse starts the acquisition of an image (level sensitive).

Free Running By default, the camera delivers continuously images with a certain frame rate, which is defined by the exposure and read-out time.

For more information and the respective timing diagrams see Section 5.4.

4.5 Configuration Interface

4.5.1 CameraLink Serial Interface

A CameraLink camera can be controlled by the user via an RS232 compatible asynchronous serial interface. This interface is contained within the CameraLink interface as shown in Fig. 4.8 and is physically not directly accessible. Instead, the serial communication is usually routed through the frame grabber. For some frame grabbers it might be necessary to connect a serial cable from the frame grabber to the serial interface of the PC.

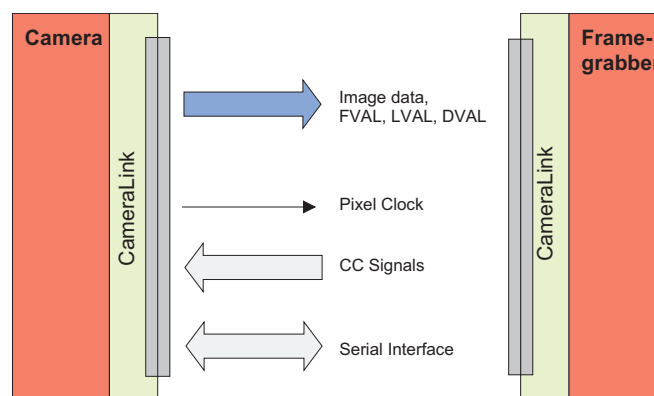

Figure 4.8: CameraLink serial interface for camera communication

To interface different cameras to different frame grabbers, the CameraLink standard defines a software API. It defines how the functions to initialise, read from, write to and close the serial interface should look. The code behind these functions is frame grabber specific and is written by the frame grabber manufacturer. The functions are then compiled into a DLL called `c1serXXX.dll`, where XXX is a unique identifier for the frame grabber manufacturer. The PFRremote camera configuration tool as well as the PFLib API use the serial interface to communicate with the camera and to control its functions. The serial interface is accessed via the `c1serXXX.dll`. Therefore, the appropriate `c1serXXX.dll` for the frame grabber manufacturer

needs to be in the same directory as the PFRremote executable (e.g. C:\Program Files\Photonfocus\PFRemote). This DLL is usually located in the windows\system32 directory after installing the frame grabber driver.

The serial configuration parameters are defined in the CameraLink standard and are as follows: 9600 baud, 1 start bit, 1 stop bit, no parity, no handshaking.

4.5.2 USB 2.0 Interface

The abbreviation USB stands for "Universal Serial Bus" and is a bus system developed in 1995 by a consortium of leading companies in the computer industry, in cooperation with Intel. The USB 1.1 specification defined the port speed to be 12 Mbit/s, the USB 2.0 specification a remarkable 480 Mbit/s. USB supports so-called "Hot-Plugging" that allows USB devices to be plugged in or out during system operation. With an image size of 750 x 400 pixels, a frame rate of about 30 frames/s can be achieved using the ISO transfer mode (max. 24 MBytes/sec), while, in isochronous mode (max. 48 MByte/s - supported only by some Intel PC chip sets) a frame rate of 60 frames/s can be reached.



The maximum speed of the USB interface (24 MByte/s or 48 MByte/s) is determined by the USB driver automatically and cannot be configured. However, the user can use external trigger for synchronisation.

Software requirements

Microsoft Windows 2000 (SP3 / SP4) or Windows XP (SP1 / SP2)



The camera can only be operated with frame grabber software from SiliconSoftware. Other frame grabber software is not supported.



The camera firmware, which is essential for the operation of the camera, is automatically transmitted to the camera via USB during the start-up of the SiliconSoftware MicroDisplay USB software. The camera must, therefore, always be connected to the USB bus during program start up; otherwise the camera will not be functional! Refer to the SiliconSoftware reference manual for further information about the Silicon Software frame grabber software.



Camera and frame grabber functions use separate SDKs. See Section 6.1.2 for more information.



After installation of the USB 2.0 device driver, *any other USB 2.0 devices connected to this controller will be ignored*. USB 1.1 devices, on the other hand, can still be operated.

Hardware requirements

A list of supported Intel chip sets can be found in B. When using one of this chip sets, the full performance of 48 Mbytes/s can be reached.

It is possible to install and operate additional USB controller (USB 1.1 and USB 2.0) plug-in cards. Additional USB 2.0 host adapters may only transfer up to 24 Mbyte/s, because they do not support the isochronous mode.

Hardware Interface

5.1 Connectors

5.1.1 CameraLink Connector

The BLIZZARD-60 CameraLink cameras are interfaced to external components via

- a CameraLink connector, which is defined by the CameraLink standard as a 26 pin, 0.5" Mini D-Ribbon (MDR) connector to transmit configuration, image data and trigger.
- a subminiature connector for the power supply, 3-pin Binder series 712

The connectors are located on the back of the camera. Fig. 5.1 shows the plugs and the status LED which indicates camera operation.

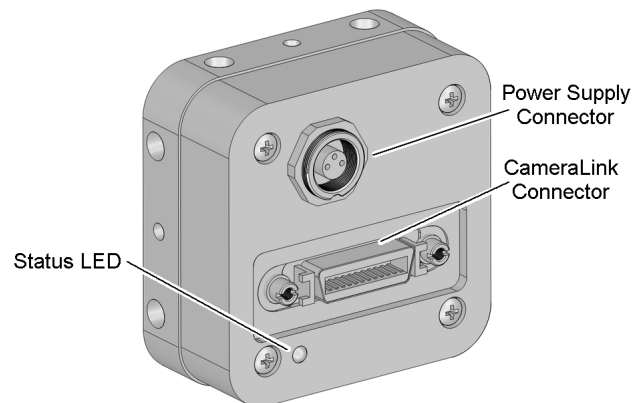

Figure 5.1: Rear view of the CameraLink camera

The CameraLink interface and connector are specified in [CL]. For further details including the pinout please refer to Appendix A. This connector is used to transmit configuration, image data and trigger signals.

5.1.2 USB 2.0 Connector

The BLIZZARD-60 USB 2.0 camera is interfaced to external components via

- a USB 2.0 (B-Type) connector (see Fig. 5.2)
- a subminiature connector for the power supply, trigger- and strobe signal, 7-pin Binder series 712



Figure 5.2: USB type-B Cable

The connectors are located on the back of the camera. Fig. 5.3 shows the plugs and the status LED which indicates camera operation.

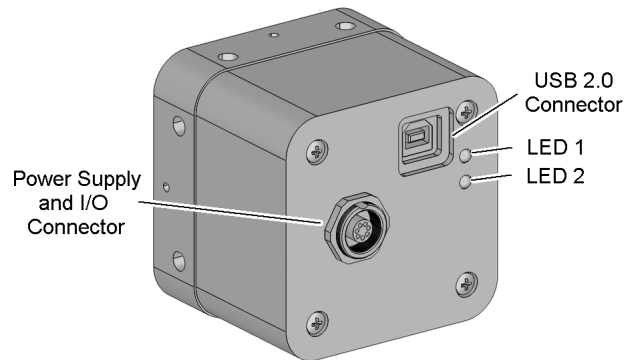

Figure 5.3: Rear view of the USB 2.0 camera

5.1.3 Power Supply

The camera requires a single voltage input (see Table 3.3). The camera meets all performance specifications using standard switching power supplies, although well-regulated linear supplies provide optimum performance.



It is extremely important that you apply the appropriate voltages to your camera. Incorrect voltages will damage the camera.



For US and Canada: Ensure a UL listed power supply is used. A suitable UL listed power supply is available from Photonfocus.

For further details including the pinout please refer to Appendix A.

5.1.4 Trigger Signals (USB only)

The power connector of the BLIZZARD-60 USB model contains an external trigger input and a strobe output.



The input voltage to the TRIGGER pin must not exceed +15V DC, to avoid damage to the optocoupler!

In order to use the strobe, the optocoupler must be powered with 5 .. 15 V DC. The STROBE signal is an open-collector output, therefore, the user must connect a pull-up resistor (> 1K) to STROBE_VDD (5 .. 15 V DC) as shown in Fig. 5.4. This resistor should be located directly at the signal receiver. The delay of the strobe pulse can be configured in the MicroDisplayUSB software.

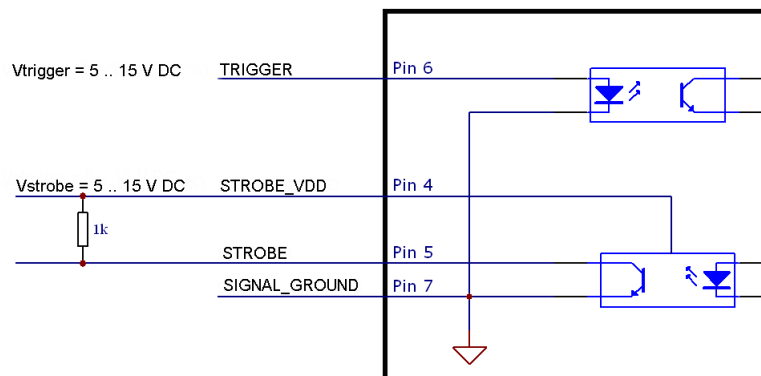

Figure 5.4: Circuit for the trigger input and strobe output signals (USB only)



The maximum sink current of the STROBE pin is 8mA. Do not connect inductive or capacitive loads, such loads will may result in damage to the optocoupler!

5.1.5 Status Indicator

A dual-color LED on the back of the camera gives information about the current status.

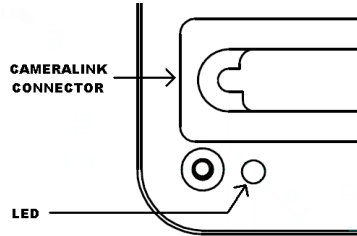

Figure 5.5: CameraLink version

LED Green	Green when an image is output. At slow frame rates, the LED blinks with the FVAL signal. At high frame rates the LED changes to an apparently continuous green light, with intensity proportional to the ratio of readout time over frame time
LED Red	Red indicates an active serial communication with the camera

Table 5.1: CameraLink Version

For the USB model, there are two LEDs:

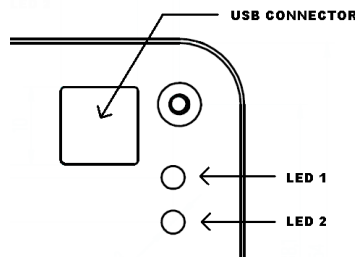

Figure 5.6: USB version

LED 1 Green	Green when a physical USB connection is established.
LED 1 Red	After the USB-firmware was uploaded to the camera by MicroDisplayUSB, the camera is ready for data transfer. The blinking frequency of the red LED indicates the current transfer mode. In ISO mode (24 MByte/s), the blinking interval is 1 Hz, in ISOCHRONOUS mode (48 Mbyte/s), it is 4 Hz.
LED 2 Green	Green when an image is output. At slow frame rates, the LED blinks with the FVAL signal. At high frame rates the LED changes to an apparently continuous green light, with intensity proportional to the ratio of readout time over frame time.
LED 2 Red	Red indicates an active serial communication with the camera.

Table 5.2: USB version

5.2 CameraLink Data Interface

The CameraLink standard defines signals for transferring the image data, control information and the serial communication.

Data Signals CameraLink data signals contain the image data. Depending on the camera model, one or more taps with variable bit resolution are used to send the image data from the camera to the frame grabber. In addition, handshaking signals such as FVAL, LVAL and DVAL are transmitted over the same physical channel.

Camera Control Information Camera control signals (CC-signals) can be defined by the camera manufacturer to provide certain signals to the camera. There are 4 CC-signals available and all are unidirectional with data flowing from the frame grabber to the camera. For example, the external trigger is provided by a CC-signal (see Table 5.3 for the CC assignments).

CC1	EXSYNC	External Trigger. May be generated either by the frame grabber itself (software trigger) or by an external event (hardware trigger).
CC2	NC	Not used
CC3	NC	Not used
CC4	NC	Not used

Table 5.3: Summary of the Camera Control (CC) signals as used by Photonfocus

Pixel Clock The pixel clock is generated by default on the camera and provided to the frame grabber for synchronisation.

Serial Communication A CameraLink camera can be controlled by the user via an RS232 compatible asynchronous serial interface. This interface is contained within the CameraLink interface and is physically not directly accessible.

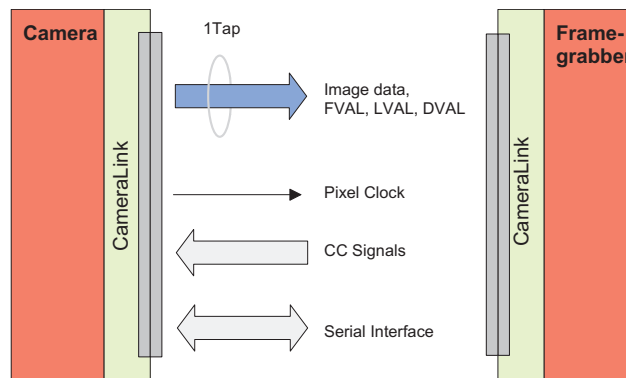

Figure 5.7: 1-tap CameraLink system

The frame grabber needs to be configured with the proper tap and resolution settings, otherwise the image will be distorted or not displayed with the correct aspect ratio. Fig. 5.7 shows symbolically a 1-tap system. For more information about taps refer to [AN021].

5.3 Read-Out Timing

5.3.1 Standard Read-out Timing

By default, the camera is in free running mode and delivers images with a certain frame rate depending on the configured exposure time without any external control signals. The sensor is operated in non-interleaved mode, which means that the sensor is read out after the preset exposure time (see 5.8). Then the sensor is reset, a new exposure starts and the readout of the image information begins again. The data is output on the rising edge of the pixel clock. The signals FRAME_VALID (FVAL) and LINE_VALID (LVAL) mask valid image information. The signal SHUTTER indicates the active integration phase of the sensor and is shown for clarity only.

Free Running

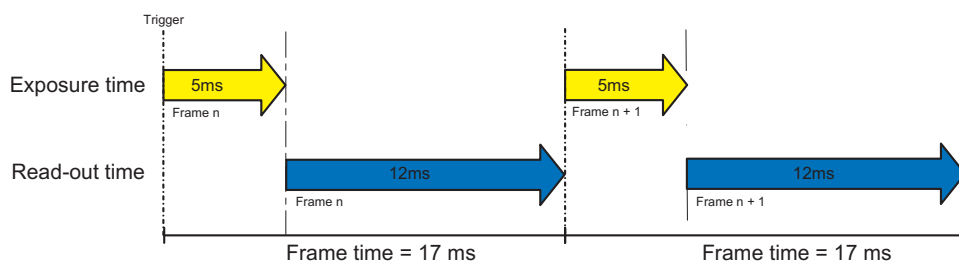

External Trigger Mode

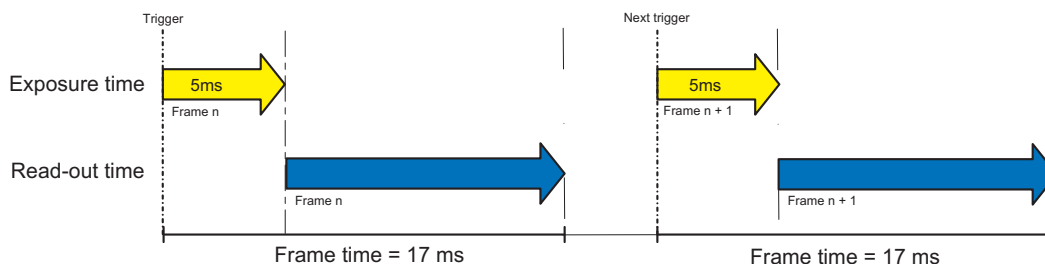

Figure 5.8: Read out timings in free running and trigger mode

Fig. 5.9 visualises the timing behaviour of the control and data signals.

Frame time	Maximum frame time is defined as exposure time plus data read out time.
Exposure time	Period during which the pixels are integrating the incoming light.
PCLK	Pixel clock on CameraLink interface
SHUTTER	Internal signal, shown only for clarity. Is 'high' during the exposure time, during which the pixels integrate the incoming light and the image is acquired.
FVAL (Frame Valid)	Is 'high' while the data of one whole frame are transferred.
LVAL (Line Valid)	Is 'high' while the data of one line are transferred. Example: To transfer an image with 750x400 pixels, there are 400 LVAL within one FVAL active high period. One LVAL lasts 750 pixel clock cycles.
DVAL (Data Valid)	Is 'high' while data are valid.
DATA	Transferred pixel values. Example: For a 750x400 pixel image, there are 750 values transferred within one LVAL active high period, or 750*400 values within one FVAL period.
Line pause	A delay before the first line and after every following line when reading out the image data.
CPRE1;CPRE2	Additional delay between signals - see Fig. 5.9.

Table 5.4: Explanation of control and data signals used in the timing diagram

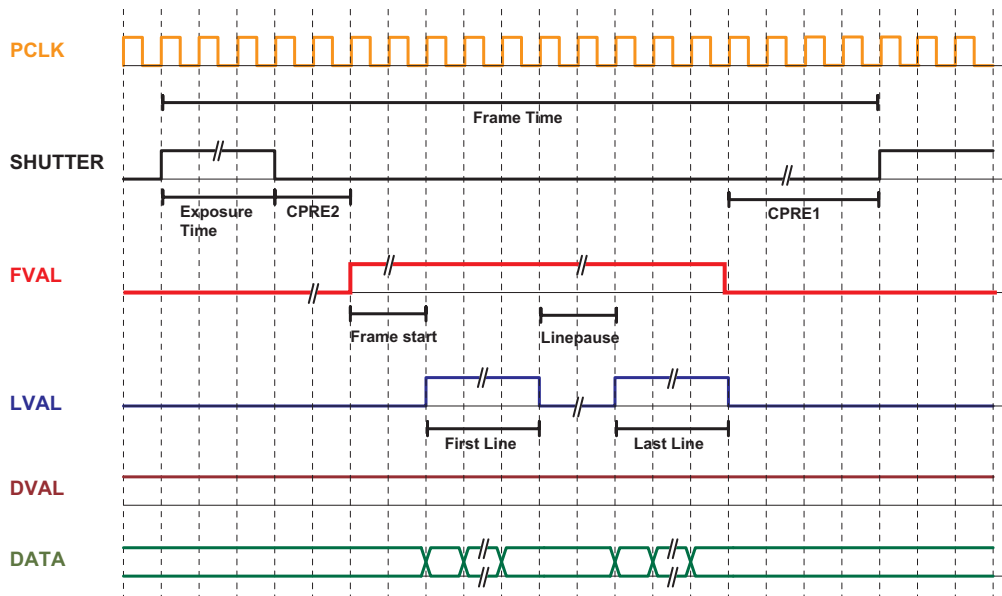

Figure 5.9: Timing diagram for free running mode

5.4 Trigger

5.4.1 Overview

A trigger is an event that starts an exposure. The trigger signal is either generated on the camera, on the frame grabber (soft-trigger) or comes from an external device such as a light barrier.

For BLIZZARD-60 cameras, there is one external trigger mode available. For the CameraLink model, the trigger signal EXSYNC must be routed by the frame grabber on CC1. For the the USB 2.0 model, see Section 5.1.4.

5.4.2 External Trigger Mode

In the external trigger mode, the image acquisition begins as soon as the external trigger pulse is high. The image is read out after the pre-set exposure time. After readout, the sensor returns to the reset state and the camera waits for a new trigger pulse (see 5.8 and Fig. 5.10). The data is output on the rising edge of the pixel clock and the CameraLink handshaking signals FRAME_VALID (FVAL) and LINE_VALID (LVAL) mask valid image information. The signal SHUTTER in Fig. 5.10 indicates the active integration phase of the sensor and is shown for clarity only.

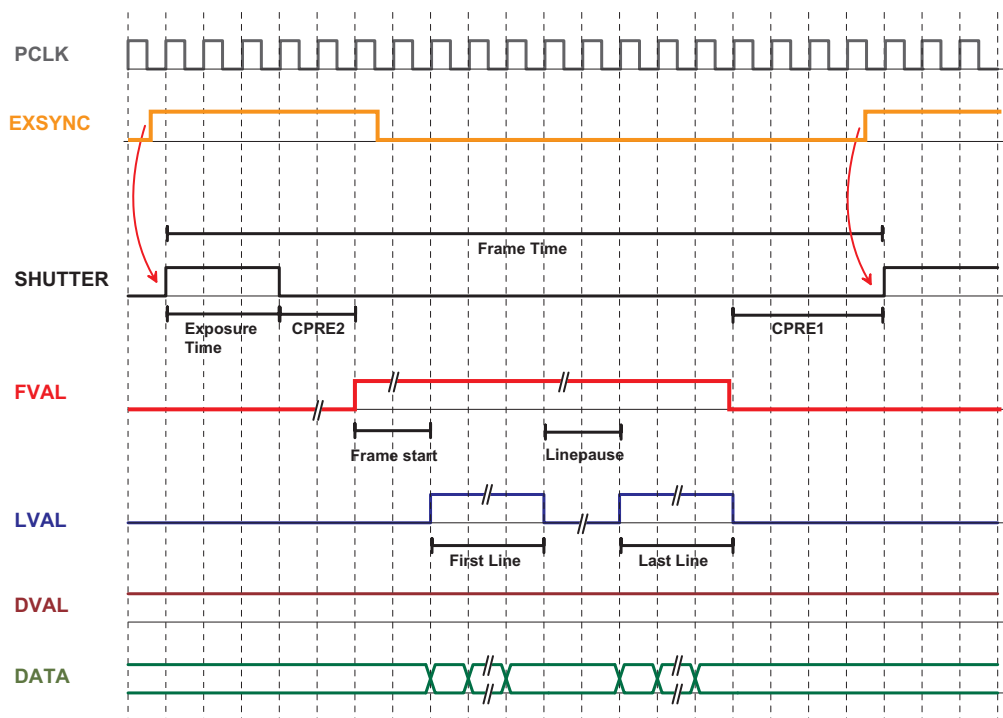

Figure 5.10: Timing diagram for external trigger mode

5.4.3 Notes on Using External Trigger

Trigger Delay (CameraLink Model)

The total delay between the trigger edge and the camera exposure consists of the delay in the framegrabber and the camera (Fig. 5.11). Usually, the delay in the frame grabber is relatively large to avoid accidental triggers caused by voltage spikes (see Fig. 5.12).

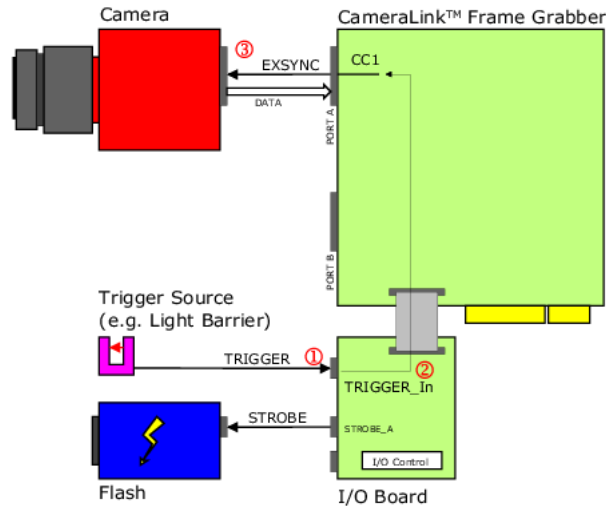

Figure 5.11: Trigger delay visualisation from the trigger source to the camera (CameraLink)

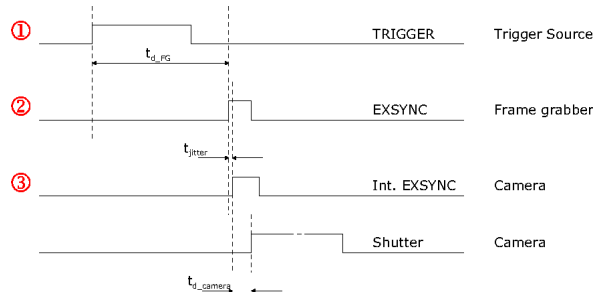

Figure 5.12: Timing diagram for trigger delay

For the delay in the framegrabber, please ask your framegrabber manufacturer. The camera delay consists of maximum 2 clock cycles, which results in the delay as shown in Table 5.5.

BLIZZARD-60 (CameraLink)	50 ns
--------------------------	-------

Table 5.5: Camera trigger delay for the BLIZZARD-60 CameraLink model

The PFRemote Control Tool

6.1 Overview

PFRemote is a graphical configuration tool for Photonfocus cameras. The latest release can be downloaded from the support area of www.photonfocus.com.

All Photonfocus cameras can be either configured by PFRemote, or they can be programmed with custom software using the PFLib SDK ([SW002]).

PFRemote is available for Windows only. For a Linux or QNX system, we provide the necessary source code to control the camera on request, but there is no graphical user interface available.



Please note that we do not provide any support for Linux or QNX.

6.1.1 CameraLink Model

As shown in Fig. 6.1, PFRemote and PFLib respectively control parameters of the camera, such as exposure time and ROI. However, to grab an image and to process it use the software or SDK that was delivered with your frame grabber.

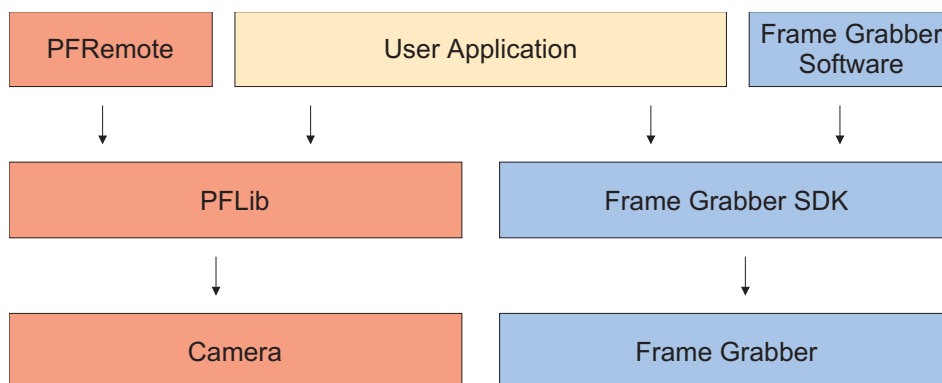

Figure 6.1: PFRemote and PFLib in context with the CameraLink frame grabber software

6.1.2 USB 2.0 Model

For the USB camera model, there is no external frame grabber necessary, as the camera connects directly to the USB 2.0 port. Instead, the frame grabber functionality was transferred into the camera.

As shown in Fig. 6.2, the camera parameters can be controlled by PFRemote and PFLib respectively. To grab an image and to process it, use the MicroDisplayUSB software or the USB SDK [SW003].

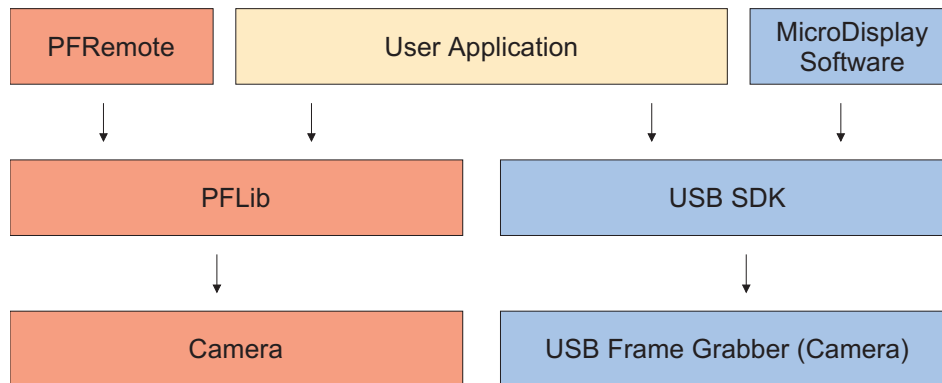

Figure 6.2: PFRemote and PFLib in context with the USB 2.0 frame grabber software

6.2 Installation Notes (CameraLink only)

Before installing PFRemote, make sure that your frame grabber software is installed correctly. The PFRemote setup wizard will ask you to choose your frame grabber. It will then copy the necessary files from your frame grabber installation to the \PFRemote directory. If your CameraLink compatible frame grabber is not listed in the setup wizard, please do the following:

- During PFRemote installation, choose "Other CameraLink compliant Grabber" when asked about the frame grabber.
- After the installation, locate a CLSER*.DLL in your frame grabber's software distribution (* matches any vendor specific extension). This file is usually located in your \windows\system32 directory or in the installation directory of the frame grabber software.
- Copy the CLSER*.DLL into the PFRemote installation directory (usually C:\Program Files\PFRemote) and rename it to CLSER.DLL.
- Start PFRemote. The port names "c10" and "c11" are displayed.

6.2.1 DLL Dependencies

Several DLLs are necessary in order to be able to communicate with the cameras:

- MVXXXXE.DLL: Specific camera DLL, e.g. BLIZZARD60.DLL.
- PFCAM.DLL: DLL handling camera detection and switching to specific camera DLL.
- CLSER.DLL: DLL for serial communication. This is a DLL which is delivered with your frame grabber software.
- COMDLL.DLL: Communication DLL. This COMDLL is not necessarily CameraLink specific, but may depend on a CameraLink API compatible DLL which should also be provided by your frame grabber manufacturer (as described above).

More information about these DLLs is available in the SDK documentation ([SW002]).

6.3 Usage

6.3.1 Camera Initialization

On start, PFRremote displays a list of available communication ports which is returned from the COMDLL. For example, a COMDLL using the CameraLink standard ports results in the display below.

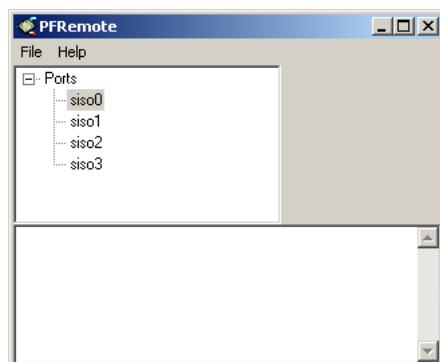

Figure 6.3: PFRremote port list

To open a camera on a specific port double click on the port name (e.g. c10). Alternatively, right click on the port name and choose **Open & Configure...**. The port is then queried for a Photonfocus compatible camera.

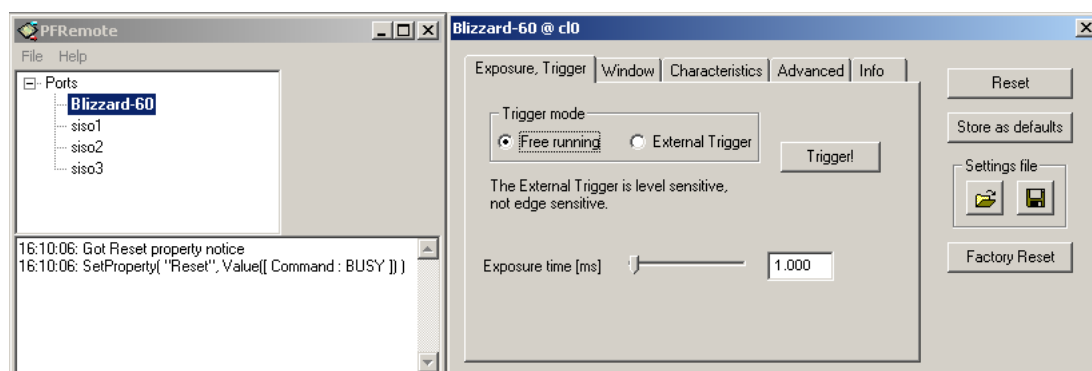

Figure 6.4: PFRremote with configuration window after camera port was opened

Once the camera has successfully been opened, the configuration dialog is displayed (Fig. 6.5). Instead of the port name, the camera model name is now displayed. Right clicking on the camera model name will show further options:

Camera Port Options Menu

Info... Shows camera information

Reset Resets the camera

Close Closes camera and frees the communication port

6.3.2 The Camera Configuration Dialog

The PFRremote configuration dialog is used to configure the camera. It uses tabs to configure the following camera parameters:

Exposure/Trigger Setting of exposure time, trigger mode, software trigger.

Window Setting of the region of interest, decimation Y 1:2.

Characteristics Setting of LinLog, analog gain, skimming, offset.

Advanced Setting of the pixel correction feature.

Info Displays information about the current camera release.

These parameters as well as the control buttons on the right side are explained in the following sections.

Common Control Buttons

Reset Reset the camera and reread the power-on values into the configuration dialog box.

Store as Defaults Store current settings in the camera EEPROM as new boot-up values.

Settings file: File Load Load default values from a file.

Settings file: File Save Save current values to a file.

Factory Reset Recover the factory settings from EEPROM (Set camera to delivery status).

Exposure and Trigger Settings

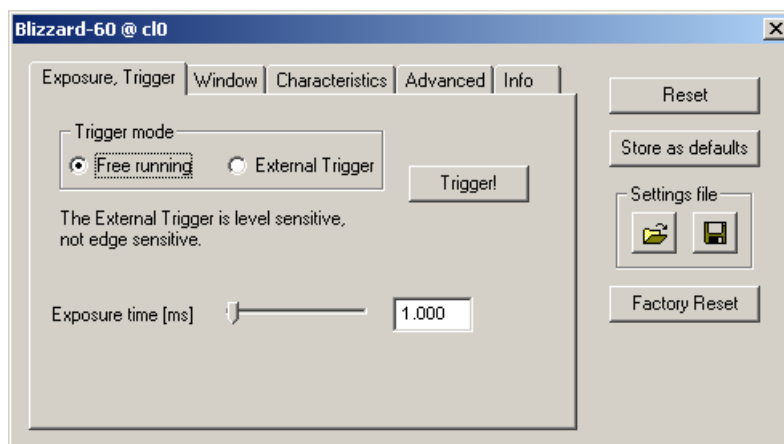

Figure 6.5: Exposure and triggering control

This register tab contains trigger and exposure settings.

Free Running The sensor delivers frames consecutively, the rate is determined by the exposure time plus readout time.

External Trigger The sensor expects a trigger signal (high active) on the trigger input. Note that if the trigger level is kept high before switching to this mode, otherwise the sensor will still stay in free running mode.

Trigger! Generate a software trigger. The trigger input level must be low.

Exposure time [ms] Configure the exposure time in milliseconds.

Window (Region of Interest, Decimation Y

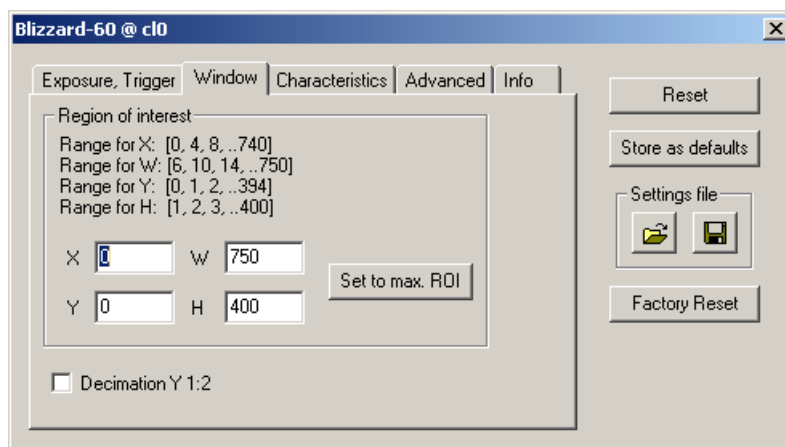

Figure 6.6: Camera window settings

The region of interest is defined as a rectangle [X, Y, W, H] where

X X-coordinate of upper left corner, starting from 0

Y Y-coordinate of upper left corner, starting from 0

W Window width

H Window height

Set to max. ROI Sets the ROI to the maximum (X = 0, Y = 0, W = 750, H = 400)

The parameters for the ROI must follow the rules according to 6.1.

Parameter	Range	Step Size
X	0, 4, 8, 12, ... 740	modulo 4
Y	6, 10, 14, 16, ... 750	4
W	0, 1, 2, 3, ... 394	1
H	0, 1, 2, 3, ... 400	1

Table 6.1: BLIZZARD-60 ROI Parameters

 Not all frame grabbers can handle ROI changes while they are running. If your frame grabber application crashes in this case, stop grabbing before adjusting the window size and make sure you have set the same window size in your frame grabber software.

The DecimationY property, if enabled, causes the sensor readout to skip every second line, which results in a decrease of the readout time and a higher achievable frame rate.

Characteristics, LinLog

Fig. 6.7 shows the properties that control the characteristic curve of the sensor. For an explanation of the LinLog feature please refer to Section 4.2.2.

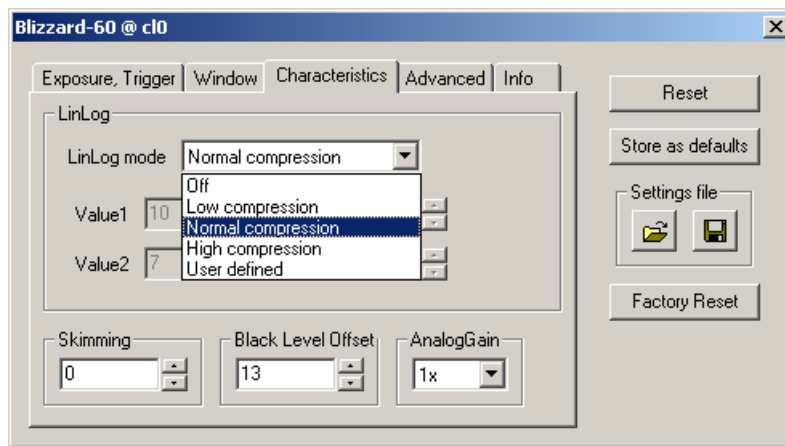

Figure 6.7: Sensor characteristics panel

There are 3 predefined LinLog settings available. Alternatively, custom settings can be created in the LinLog "User defined" Mode.

LinLog Mode Off: LinLog is disabled. Low/Normal/High compression: Three LinLog presets.
User defined: Time1, Time2, Value1 and Value2 defined by user.

Skimming Skimming value. Skimming is disabled if set to 0. See Section 4.2.3

Black Level Offset Black level offset value. Use this to adjust the black level.

AnalogGain Change the analog gain of the sensor.

Advanced

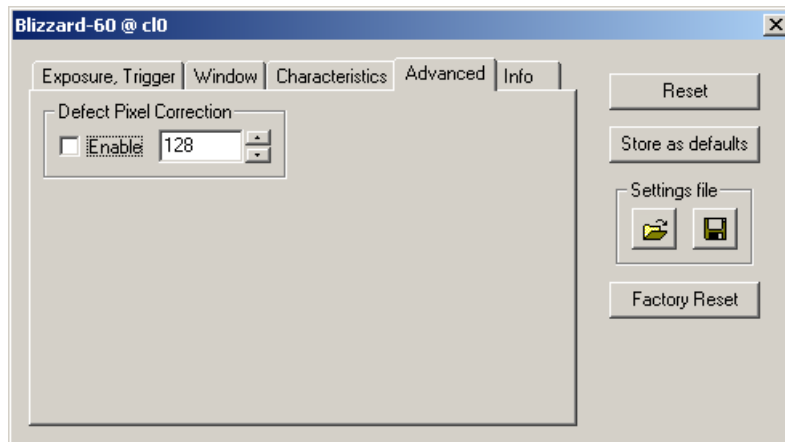

Figure 6.8: Advanced panel

Defect Pixel Correction The defect pixel correction can be enabled in this dialog. The configurable value (e.g. 128 in Fig. 6.8) corresponds to the user-defined threshold, that is described in Section 4.2.4.



Low threshold values (< 50) will smooth the image because the correction acts as a low pass filter.

Info

Fig. 6.9 shows camera specific information such as type code, serial number and firmware revision of the microcontroller.

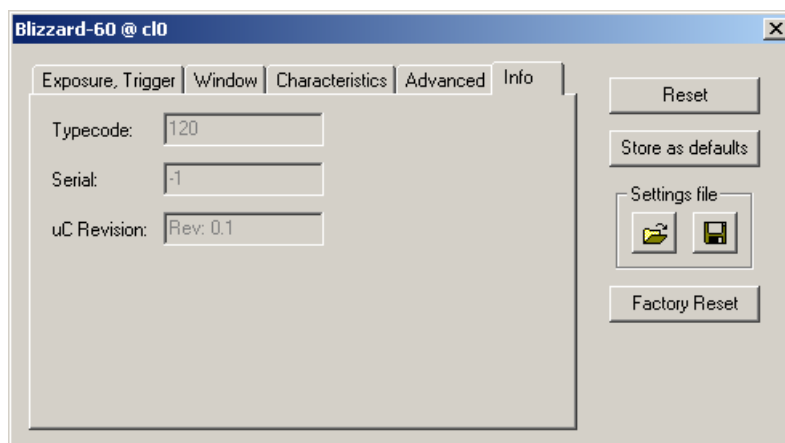

Figure 6.9: Info panel

Typecode The type code of the connected camera.

Serial Serial number of the connected camera.

uC Revision Firmware revision of built-in microcontroller of the connected camera.



For any support requests, please enclose the type code, the serial number and the uC revision.

Mechanical and Optical Considerations

7.1 Mechanical Dimensions

The general mechanical dimensions of the camera are listed in Table 3.3.

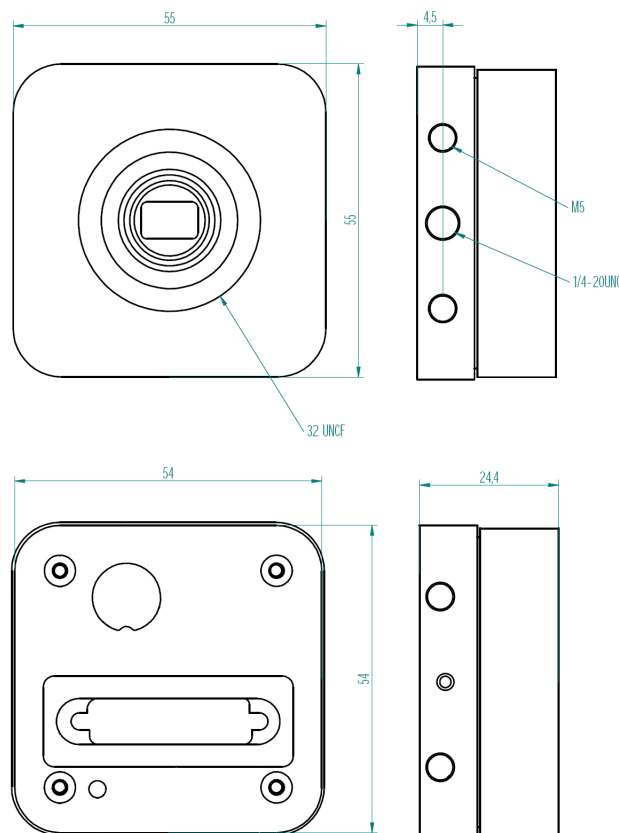

Figure 7.1: Mechanical dimensions of the BLIZZARD-60 model with CameraLink interface

During storage and transport, the camera should be protected against vibration, shock, moisture and dust. The original packing protects the camera adequately from vibration and shock during storage and transport. Please either retain this packing for possible later use or dispose of it according to local regulations.

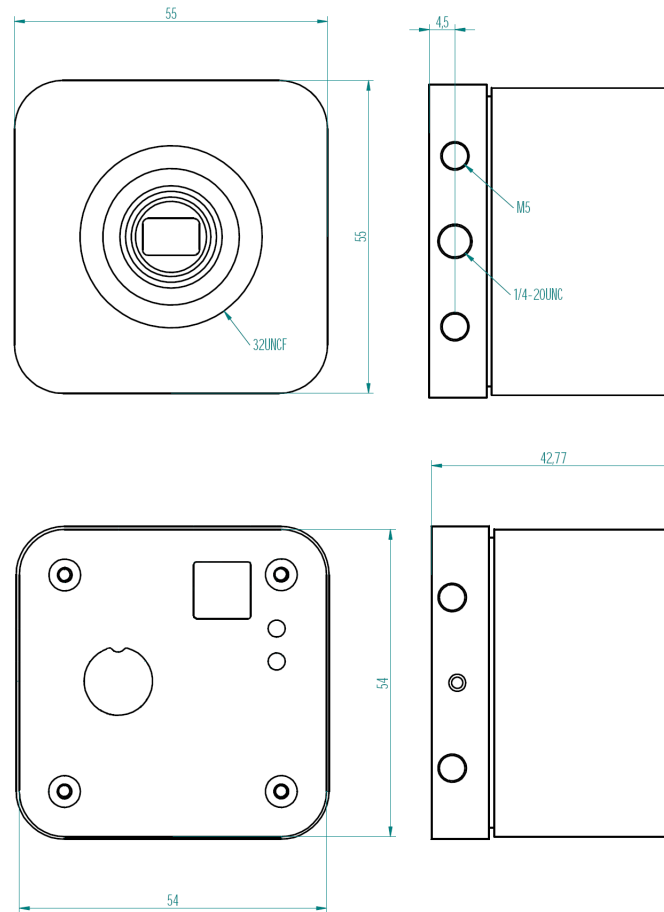

Figure 7.2: Mechanical dimensions of the BLIZZARD-60 model with USB interface

7.2 Optical Interface

7.2.1 Mounting the Lens

Remove the protective cap from the C-/CS-mount thread of the camera and install the lens. When removing the protective cap or changing the lens, the camera should always be held with the opening facing downwards to prevent dust from the environment falling onto the CMOS sensor. If the lens is removed, the protective cap should be refitted. If the camera is operated in a dusty environment, we recommend the use of a constant stream of clean air at the front of the objective.

7.2.2 Cleaning the Sensor

The sensor is part of the optical path and should be handled like other optical components: with extreme care.

Dust can obscure pixels, producing dark patches in the images captured. Dust is most visible when the illumination is collimated. Dark patches caused by dust or dirt shift position as the angle of illumination changes. Dust is normally not visible when the sensor is positioned at the

exit port of an integrating sphere, where the illumination is diffuse.

1. The camera should only be cleaned in ESD-safe areas by ESD-trained personnel using wrist straps. Ideally, the sensor should be cleaned in a clean environment. Otherwise, in dusty environments, the sensor will immediately become dirty again after cleaning.
2. Use a high quality, low pressure air duster (e.g. Electrolube EAD400D compressed air spray) to blow off loose particles. This step alone is usually sufficient to clean the sensor of the most common contaminants.



Workshop air supply is not appropriate and may cause permanent damage to the sensor.

3. If further cleaning is required, use a suitable lens wiper or Q-Tip moistened with an appropriate cleaning fluid to wipe the sensor surface as described below. Examples of suitable lens cleaning materials are given in Table 7.1. Cleaning materials must be ESD-safe, lint-free and free from particles that may scratch the sensor surface.



Do not use ordinary cotton buds. These do not fulfil the above requirements and permanent damage to the sensor may result.

4. Wipe the sensor carefully and slowly. First remove coarse particles and dirt from the sensor using Q-Tips soaked in 2-propanol, applying as little pressure as possible. Using a method similar to that used for cleaning optical surfaces, clean the sensor by starting at any corner of the sensor and working towards the opposite corner. Finally, repeat the procedure with methanol to remove streaks. It is imperative that no pressure be applied to the surface of the sensor or to the black globe-top material (if present) surrounding the optically active surface during the cleaning process.

Product		Supplier	Remark
Anticon Gold 9"x 9"	Wiper	Milliken	ESD safe and suitable for class 100 environments.
TX4025	Wiper	Texwipe	
Transplex	Swab	Texwipe	
Small Q-Tips SWABS BB-003	Q-tips	Hans J. Michael GmbH, Germany	
Large Q-Tips SWABS CA-003	Q-tips	Hans J. Michael GmbH, Germany	
Point Slim HUBY-340	Q-tips	Sharp	
Methanole	Fluid	Jonson Matthey GmbH, Germany	Semiconductor Grade 99.9% min (Assay), Merk 12,6024, UN1230, slightly flammable and poisonous.
2-Propanole (Iso-Propanole)	Fluid	Jonson Matthey GmbH, Germany	Semiconductor Grade 99.5% min (Assay) Merk 12,5227, UN1219, slightly flammable.

Table 7.1: Recommended materials for sensor cleaning

For cleaning the sensor, Photonfocus recommends the products available from the suppliers as listed in Table 7.1.

7.3 Compliance

CE Compliance is currently being tested.

Warranty

The manufacturer alone reserves the right to recognize warranty claims.

8.1 Warranty Terms

The manufacturer warrants to distributor and end customer that for a period of two years from the date of the shipment from manufacturer or distributor to end customer (the "Warranty Period") that:

- the product will substantially conform to the specifications set forth in the applicable documentation published by the manufacturer and accompanying said product, and
- the product shall be free from defects in materials and workmanship under normal use.

The distributor shall not make or pass on to any party any warranty or representation on behalf of the manufacturer other than or inconsistent with the above limited warranty set.

8.2 Warranty Claim



The above warranty does not apply to any product that has been opened, modified or altered by any party other than manufacturer, or for any defects caused by any use of the product in a manner for which it was not designed, or by the negligence of any party other than manufacturer.

Pinouts

A.1 Power Supply

The power supply plugs are available from Binder connectors at www.binder-connector.de.



It is extremely important that you apply the appropriate voltages to your camera. Incorrect voltages will damage or destroy the camera.



For US and Canada: Ensure a UL listed power supply is used. A suitable UL listed power supply is available from Photonfocus.

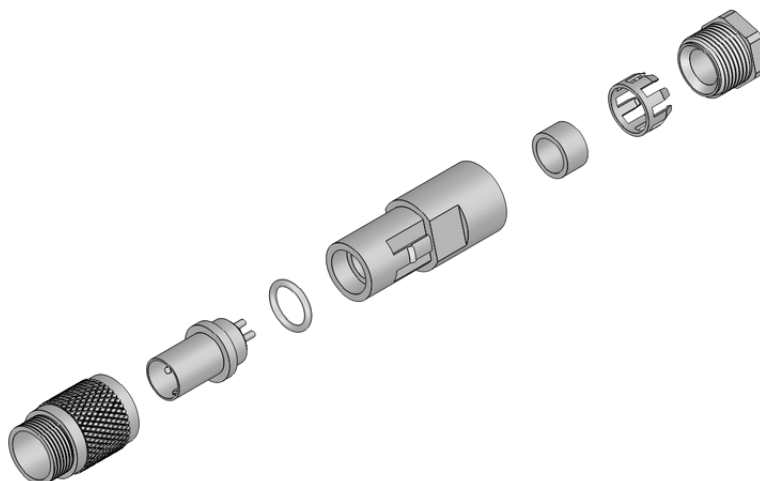

Figure A.1: Power connector assembly

A.1.1 Power Supply Connector for CameraLink Model

For the sake of completeness, A.1 summarizes the order codes of the power supply connector.

Connector Type	Order Nr.
3-pole, plastic	99-0405-00-03
3-pole, metal	99-0405-10-03

Table A.1: Power supply connectors (Binder subminiature series 712)

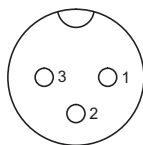

Figure A.2: Power Supply plug for CameraLink model, 3-pole (rear view, solder side)

Pin	I/O Type	Name	Description
1	PWR	NC	Not connected
2	PWR	GND	Ground
3	PWR	VDD	+12 V DC ($\pm 10\%$)

Table A.2: Power supply plug pin assignment for CameraLink model

A.1.2 Power Supply Connector for USB Model

For the sake of completeness, A.3 summarizes the order codes of the power supply connector.

Connector Type	Order Nr.
7-pole, plastic	99-0421-00-07
7-pole, metal	99-0421-10-07

Table A.3: Power supply connectors (Binder subminiature series 712)

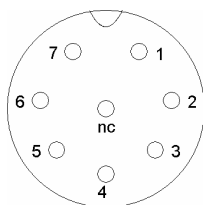

Figure A.3: Power supply plug for USB 2.0 model, 7-pole (rear view of plug, solder side)

Pin	I/O Type	Name	Description
1	PWR	VDD	+12 V DC ($\pm 10\%$)
2	PWR	GND	Ground
3	-	NC	Not connected
4	PWR	STROBE-VDD	+5 .. +15 V DC
5	O	STROBE	Strobe control (opto-isolated)
6	I	TRIGGER	External trigger (opto-isolated), +5 .. +15V DC
7	PWR	GROUND	Signal ground (for opto-isolated strobe signal)

Table A.4: Power supply plug pin assignment for USB 2.0 model

A.2 CameraLink

The pinout for the CameraLink 26 pin, 0.5" Mini D-Ribbon (MDR) connector is according to the CameraLink standard ([CL]) and is listed here for reference only.

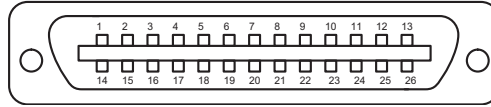

Figure A.4: CameraLink cable 3M MDR-26 plug (both ends)

PIN	IO	Name	Description
1	PW	SHIELD	Shield
2	O	N_XD0	Negative LVDS Output, CameraLink Data D0
3	O	N_XD1	Negative LVDS Output, CameraLink Data D1
4	O	N_XD2	Negative LVDS Output, CameraLink Data D2
5	O	N_XCLK	Negative LVDS Output, CameraLink Clock
6	O	N_XD3	Negative LVDS Output, CameraLink Data D3
7	I	I_SERTOCCAM	Positive LVDS Input, Serial Communication to the camera
8	O	N_SERTOFG	Negative LVDS Output, Serial Communication from the camera
9	I	N_CC1	Negative LVDS Input, CC1
10	I	N_CC2	Positive LVDS Input, CC2
11	I	N_CC3	Negative LVDS Input, CC3
12	I	P_CC4	Positive LVDS Input, CC4
13	PW	SHIELD	Shield
14	PW	SHIELD	Shield
15	O	P_XD0	Positive LVDS Output, CameraLink Data D0
16	O	P_XD1	Positive LVDS Output, CameraLink Data D1
17	O	P_XD2	Positive LVDS Output, CameraLink Data D2
18	O	P_XCLK	Positive LVDS Output, CameraLink Clock
19	O	P_XD3	Positive LVDS Output, CameraLink Data D3
20	I	N_SERTOCCAM	Negative LVDS Input, Serial Communication to the camera
21	O	P_SERTOFG	Positive LVDS Output, Serial Communication from the camera
22	I	P_CC1	Positive LVDS Input, CC1
23	I	N_CC2	Negative LVDS Input, CC2
24	I	P_CC3	Positive LVDS Input, CC3
25	I	N_CC4	Negative LVDS Input, CC4
26	PW	SHIELD	Shield
S	PW	SHIELD	Shield

Table A.5: Pinout CameraLink connector

A.3 USB 2.0

The USB 2.0 interface and connector were developed by a group of companies (Intel, Agere Systems, NEC, Hewlett-Packard, Philips, etc.) which are now organized in the USB Implementers Forum (www.usb.org).

The USB connector is used to transmit configuration signals and image data.

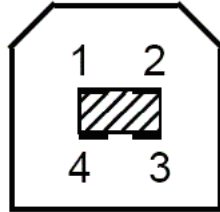

Figure A.5: USB type B connector (front view)

PIN	IO	Name	Description
1	PWR	VBUS	+5V power supply
2	I/O	DATA -	Negative Data
3	I/O	DATA +	Positive Data
4	PWR	GND	Ground

Table A.6: Pinout USB 2.0 connector

USB compatibility

B.1 Hardware requirements

To reach the full performance of 48 Mbyte/s (isochronous mode), a PC Mainboard with USB2.0 ports with Intel chip set supporting ICH4, ICH5 or ICH6 is mandatory.



Intel provides a small program (chiputil.exe) to determine the exact nature of the chip set being used. This can be downloaded from:

<ftp://aiedownload.intel.com/df-support/7355/eng/chiputil.exe>

Alternative link: http://downloadfinder.intel.com/scripts-df/support_intel.asp
(search for 'chiputil')

In the tables B.2, B.1, B.4 and B.3 there is a summary of common Intel chip sets that feature an ICH4, ICH5 or ICH6 controller.



This chip set list is not exhaustive; status April 2005.

<i>Chipset</i>	<i>Type of I/O Controller Hub</i>
Intel® 925XE Express	ICH6 / ICH6-R
Intel® 925X Express	ICH6 / ICH6-R
Intel® 915G Express	ICH6 / ICH6-R
Intel® 915GV Express	ICH6 / ICH6-R
Intel® 915GL Express	ICH6 / ICH6-R
Intel® 915P Express	ICH6 / ICH6-R
Intel® 915PL Express	ICH6 / ICH6-R
Intel® 875P	ICH5 / ICH5-R
Intel® 865G	ICH5 / ICH5-R
Intel® 865GV	ICH5 / ICH5-R
Intel® 865P	ICH5 / ICH5-R
Intel® 865PE	ICH5 / ICH5-R

Table B.1: Performance / Mainstream desktop chip sets

<i>Chipset</i>	<i>Type of I/O Controller Hub</i>
Intel® 925X Express	ICH6-R
Intel® 875P	ICH5-R
Intel® E7205	ICH4
Intel® E7505	ICH4
Intel® E7520	ICH5-R
Intel® E7525	ICH5-R
Intel® E7320	ICH5-R

Table B.2: Server / Workstation chip sets

<i>Chipset</i>	<i>Type of I/O Controller Hub</i>
Intel® 915GM Express	ICH6-M
Intel® 915GMS Express	ICH6-M
Intel® 915PM Express	ICH6-M
Intel® 910GML Express	ICH6-M
Intel® 855GME	ICH4-M
Intel® 855GM	ICH4-M
Intel® 855PM	ICH4-M
Intel® 845MP	ICH4-M
Intel® 845MZ	ICH4-M
Intel® 852GME	ICH4-M
Intel® 852GMV	ICH4-M
Intel® 852GM	ICH4-M
Intel® 852PM	ICH4-M

Table B.3: Notebook / Mobile chip sets

<i>Chipset</i>	<i>Type of I/O Controller Hub</i>
Intel® 910GL Express	ICH6 / ICH6-R
Intel® 848P	ICH5 / ICH5-R
Intel® 845G	ICH4
Intel® 845GV	ICH4
Intel® 845GE	ICH4
Intel® 845GL	ICH4
Intel® 845PE	ICH4
Intel® 845E	ICH4

Table B.4: Value Desktop chip sets

It is possible to install and operate additional USB controller (USB1.1 and USB2.0) plug-in cards. Additional USB 2.0 host adapters may only transfer up to 24 Mbyte/s. because they do not support the isochronous mode.

The following add-on cards were tested at Photonfocus (this list is not exhaustive; status April 2005):

Manufacturer	Type	Chipset	Speed (MBytes/sec.)	Supported?
Planet	UIH-420	VIA VT6202	24	Yes (see note)
DeLock	89028	NEC D720100AGM	-	Not yet
Digitus	2-Port USB2.0 card	NEC D720101GJ	-	Not yet
Digitus	5-Port USB2.0 card	NEC D720101GJ	-	Not yet
Adaptec	AUA-5100	NEC D720101GJ	-	Not yet

Table B.5: Add-On PCI cards



The VIA chipset (VT6202) works but the isochronous mode (48 MByte/s) is not supported. Thus, only 24 MByte/s can be transmitted.



After installation of the USB 2.0 device driver, *any other USB 2.0 devices connected to this controller will be ignored*. USB 1.1 devices, on the other hand, can still be operated.

Literature and Links

CL CameraLink Specification, October 2000

SW002 PFLib SDK Documentation, Photonfocus, July 2005

AN001 Application Note "LinLog", Photonfocus, December 2002

AN021 Application Note "CameraLink", Photonfocus, July 2004

SW003 Grab Module SDK USB 2.0, Silicon Software, November 2004

Revision History

Revision	Date	Changes
1.0	August 2005	First release